

OXY2 **Sh**
Instruction Manual

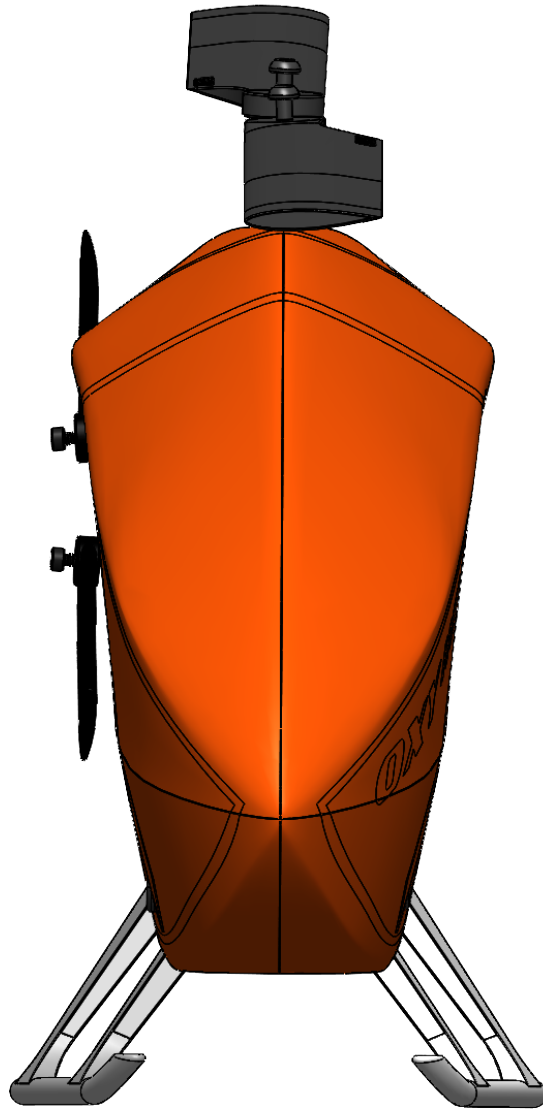

VERY IMPORTANT NOTE:

- Visit the Oxy Heli web site www.oxyheli.com to download the latest version of the manual.
- Inside Box 2 you will find your serial number card. Please take a moment to visit the Oxy Heli web site and follow the instructions to register your helicopter and serial number.
- It is important you take few minutes to register your helicopter and serial number with us. This is the only way to be in contact with us to receive news, promotional information and technical tips.
- We will also choose five serial numbers each year that will win a discount coupon worth 200USD each to spend at the Oxy Heli or Lynx Heli web sites.
- Thank you for your purchase, and we wish you the best enjoyment with your new Oxy 2 Helicopter.

INDEX

Chapter 1 - Specifications	page 2	Chapter 13 - Flybarless Installation	page 27
Chapter 2 - Important Notes	page 3	Chapter 14 - Servo & Servo Rod Preparation	page 28
Chapter 3 - Required Tools for Assembly	page 4	Chapter 15 - Cyclic Servo Installation	page 29
Chapter 4 - What's Inside The Box	page 5 - 6	Chapter 16 - Tail Servo Installation	page 30
Chapter 5 - Pinion Selection & RPM	page 7	Chapter 17 - Landing Gear & Battery Installation	page 31
Chapter 6 - Tail Assembly	page 8 - 13	Chapter 18 - Main & Tail Blades Installation	page 31
Chapter 7 - Main Frame Assembly	page 14 - 18	Chapter 19 - Adjustment Servo with Leveler	page 32-33
Chapter 8 - Align and Lock Frame Panel	page 19	Chapter 20 - Exploded View	page 34-37
Chapter 9 - Transmission Assembly	page 20-21		
Chapter 10 - Belt Tension & Adjustment	page 22		
Chapter 11 - Main Rotor Assembly	page 23-25		
Chapter 12 - ESC Installation	page 26		

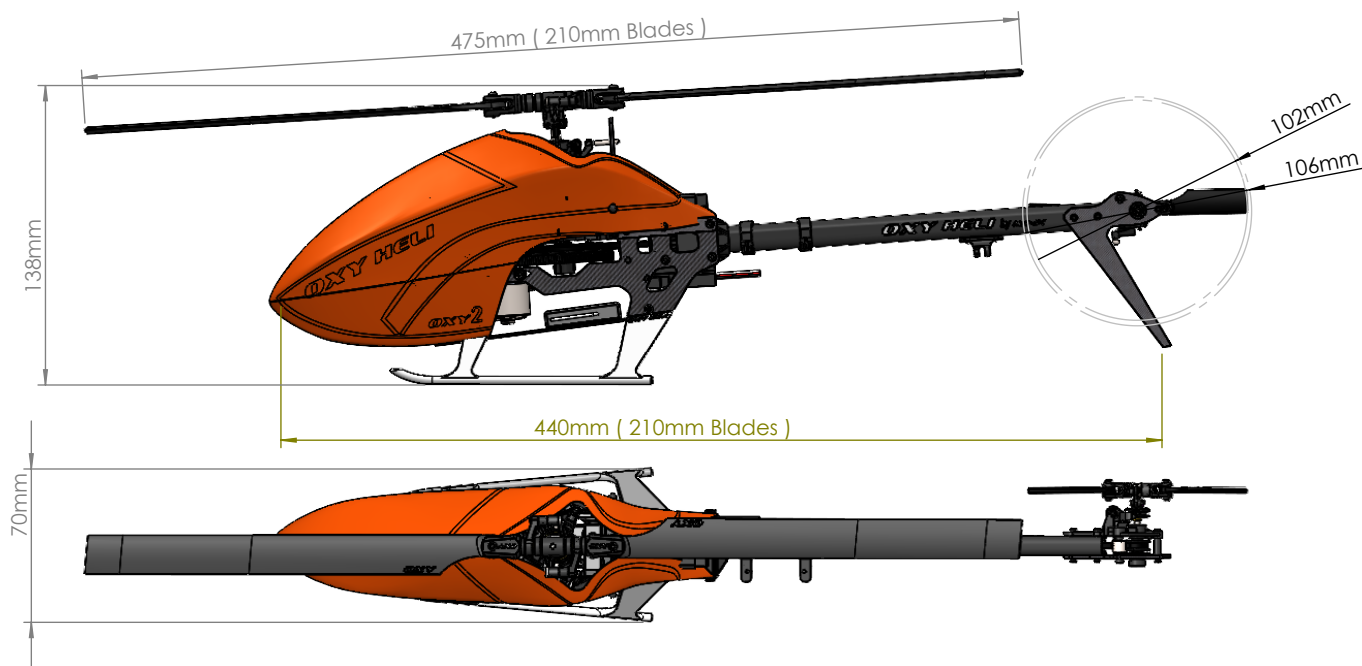
SPECIFICATIONS

-Standard main rotor diameter	: 455mm (with 205mm blades).
-Standard main blade length	: 190mm/210mm
-Main Grip Clamping	: M2 / 3.2 mm root.
-Standard tail rotor diameter	: 102/106 mm.
-Standard tail blade length	: 38/41 mm.
-Tail Blade Clamping	: M1.6 / 3 mm root.
-Weight	: 274g (ready to fly excluding batteries)
-Maximum motor size	: diameter 26mm.
-Maximum battery size	: length 72mm, height 25mm, width 35mm, weight 114gr
-Recommend battery	: 850 45C -1000 mAh 3s 40C max size.....

IMPORTANT NOTE:

This model helicopter has been designed and produced to be a high performance 3D machine. With its simple design and low parts count, pilots of all skill levels will appreciate its easy repairability. This is not a toy. Please take care assembling the model, and take care and responsibility when you fly it. We take no responsibility for any damage or injuries, either direct or consequential, from the use of this product. If you are not experienced in the assembly and flying of a high performance model helicopter we recommend you seek the assistance of an experienced pilot. Above all, fly safely and we hope you enjoy this model.

SAFETY GUIDELINES:

Only fly this model in areas designated for the use of model aircraft. Ensure you obtain indemnity insurance, normally available through your National model aircraft association. Remain at least 6 meters (20 feet) from the model at all times. Never allow spectators or animals any closer than 30 meters (100 feet) from the model.

NOTES FOR ASSEMBLY:

Please read this instruction manual fully before beginning assembly of this model helicopter. Be sure to use quality tools during the assembly process, and remember not to overtighten small fasteners. Note the following symbols which are used in this manual. Use thread lock sparingly where indicated. If you are unsure about an assembly step, please seek the advice of an experienced pilot. Warranty on any parts is only applicable prior to assembly of the part on the model.

NONE OF THE PRE ASSEMBLED PARTS HAVE THREAD LOCK ON THE SCREWS. IS IMPORTANT TO READ AND FOLLOW THE ASSEMBLY NOTES IN EACH STEP. INCORRECT ASSEMBLY OR NOT USING THREAD LOCK WILL CAUSE A CRASH OR INJURY.



Important note

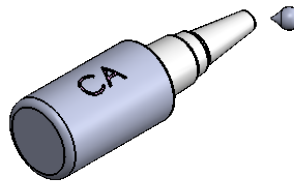

Use CA Glue

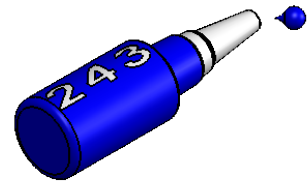

Use Loctite 243 Medium Strength

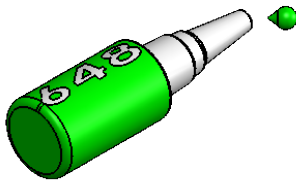

Use Loctite 648 Bonding

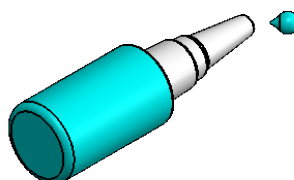

Use Silicone Grease

TOOLS REQUIRED

Small Tip - Flat Screw Driver

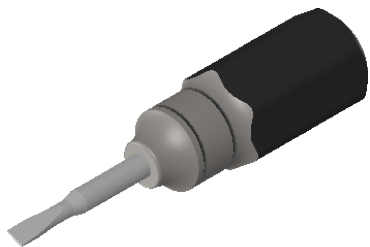

1.5mm Hex Screw Driver
(High quality)

 Two Tools Required

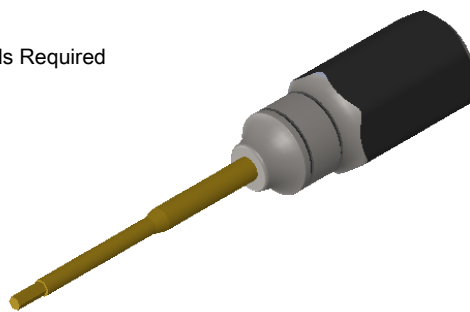

1.3mm Hex Screw Driver
(High quality)

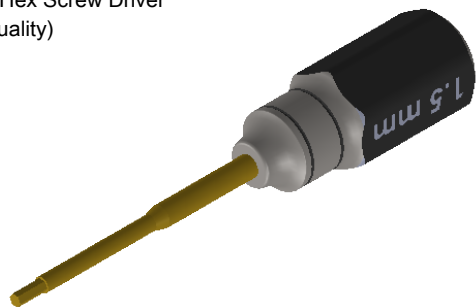

Philips head screw driver

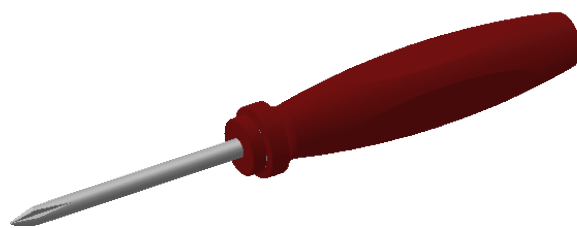

Needle nose pliers

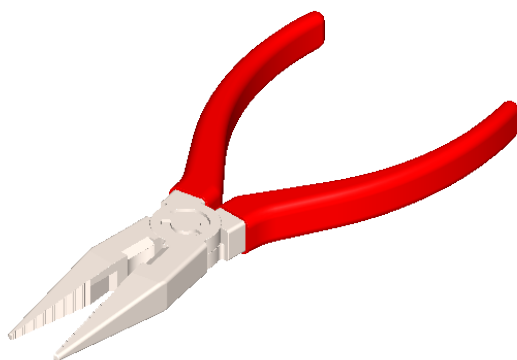

Uniball Pliers

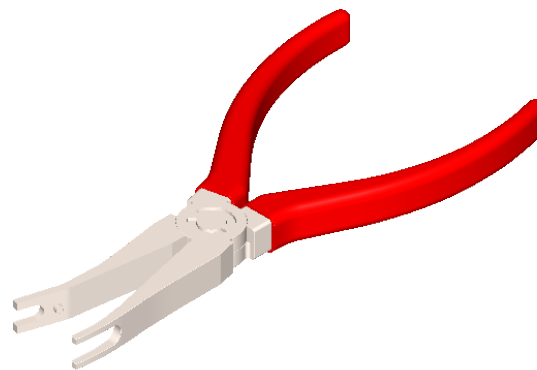

Caliper

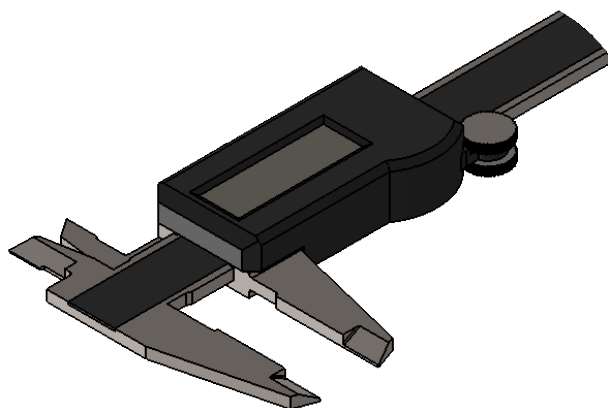

INSIDE THE MAIN BOX



Canopy,
BOX 1-1,
Box 1/Bag 11 Main Frame Set,
Box 1/Bag 10 Landing Gear Set,
Tail Set Assembly Parts.

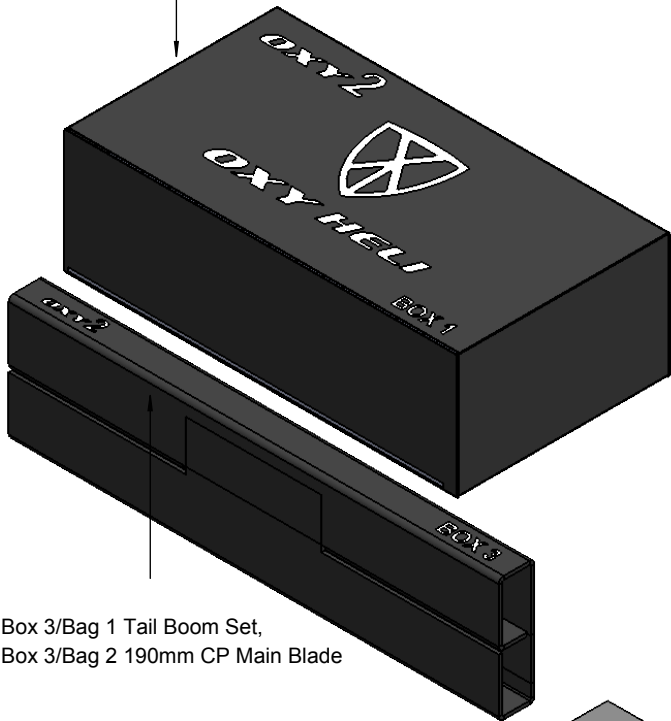

Box 3/Bag 1 Tail Boom Set,
Box 3/Bag 2 190mm CP Main Blade

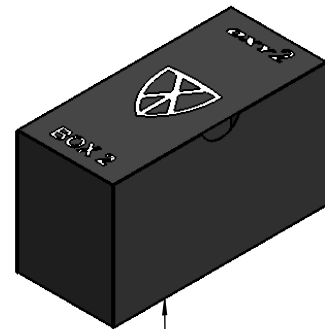

Serial Number Card,
Box 2/Bag 1 Boom Clamp Set,
Box 2/Bag 2 Battery Tray Set,
Box 2/Bag 3 Main Gear Set,
Box 2/Bag 4 Accessories,
Box 2/ Bag 5 Extra Hardware,

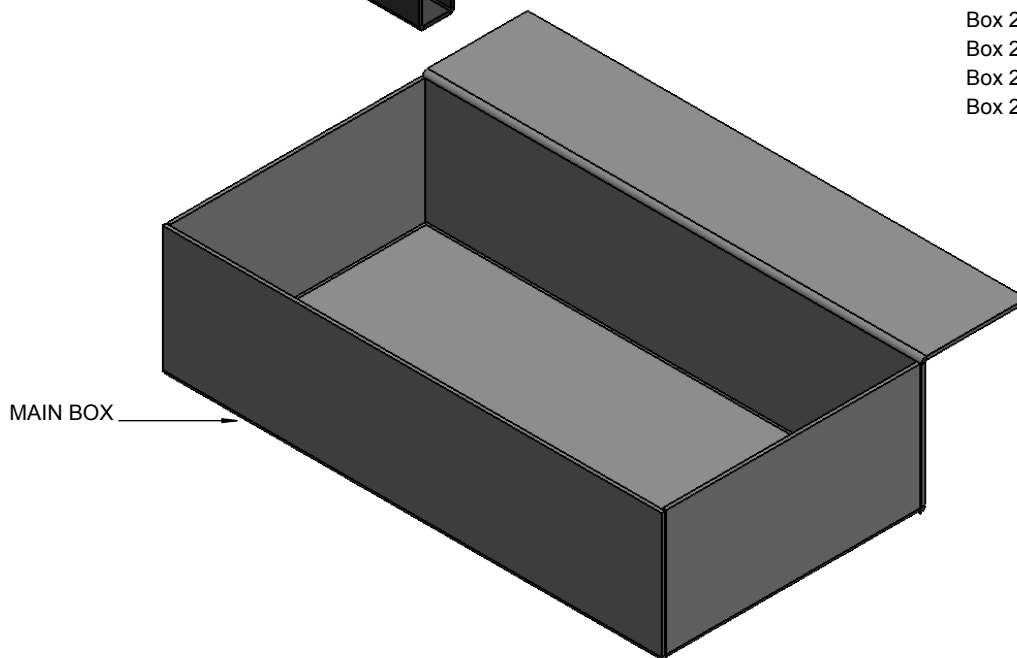

MAIN BOX

INSIDE THE BOX 1

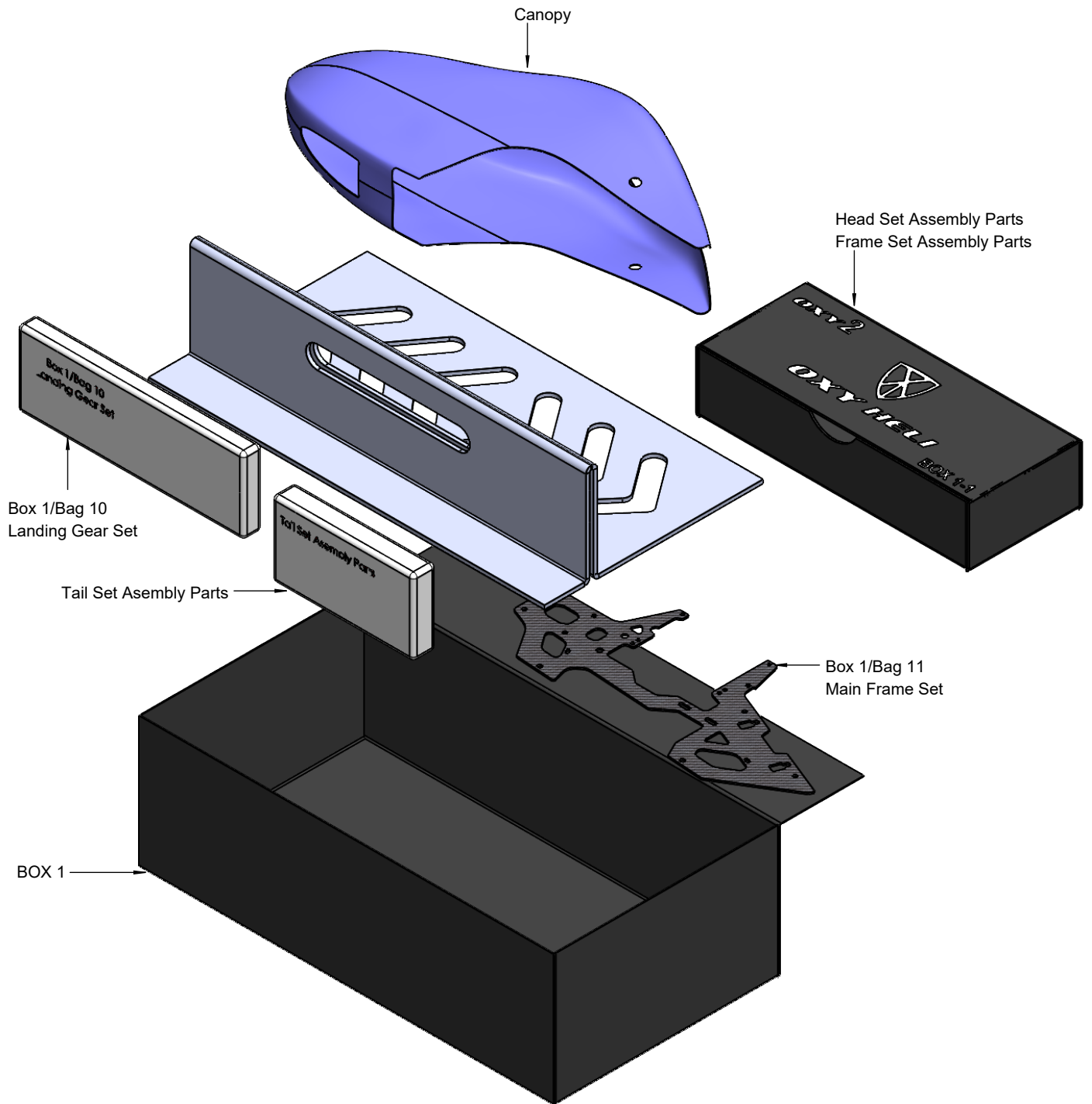

OXY 2 POWER SYSTEM AND HEAD SPEED SET-UP

In order to choose the best setup for your Oxy 2, and optimize performance, it is important to know some basic information:

1- Motor Kv – Min 3600 - Max 6000 - See your motor specification

2- Battery Pack – (3s or 4s)

3- Your target head speed

If you use a head speed calculator, use **113T** for the straight main gear and one of the available pinions 10T – 11T – 12T – 13T – 14T – 15T – 17T .

The kit comes with one pinions (11T-2mm Shaft) which enables a wide head speed range with 3s batteries and 5500Kv Motor perfect for novice and expert pilots.

Oxy 2 Gear Ratio Chart

10	11.000
11	10.000
12	9.167
13	8.462
14	7.857
16	6.875
18	6.111

Oxy 2 Fly Style / Head Speed / Main Blade / Tail Blade / Max Pitch suggestion chart:

	Fly Style	Head Speed		Main Blade	Pitch	Tail Blade	Tail Pulley
OXY2 190mm	Hover	3500	4000	190 CP	+ 10 / -3	41	16 T
	Fly 2D	4000	4500	190 CP	+ 10 / -5	41	16 T
	Soft 3D	4500	5000	190 CP	+/- 13	38	16 T
	Hard 3D	5000	5500	190 CP	+/- 14	38	16 T
	Extreme 3D	5500	6000	190 CP	+/- 14	38	16 T

	Fly Style	Head Speed		Main Blade	Pitch	Tail Blade	Tail Pulley
OXY2 210mm	Hover	3300	3750	210 CF	+ 10 / -3	41	15T
	Fly 2D	3750	4200	210 CF	+ 10 / -5	41	15T
	Soft 3D	4200	4650	210 CF	+/- 13	41	16 T
	Hard 3D	4650	5100	210 CF	+/- 14	41	16 T
	Extreme 3D	5100	5550	210 CF	+/- 14	41	16 T

Head Speed Note: Although Oxy 2 can handle very high Head Speed, we suggest not to exceed 5000 RPM to maintain a good compromise btw performances and efficiency.

Over 5000 rpm to Max 5500 rpm we recommend to use CNC Main Grip SP-OXY2-002 - OXY2-FE - CNC Main Grip.

Configuration examples

Since the Oxy2 is a high performance 3D RC helicopter, we suggest using high quality power components including motor, battery and ESC. Remember the Oxy 2 is a 200 class heli – use light components to maximize flight time and performance.

Here are some suggestions:

- Motor: Suggested KV 3600KV to 6000KV, 16-11 to 19-12 caliber series (stator diameter – stator length).
- Battery: 3 or 4S with capacity from 800 to 1000mAh / 45C discharge rate. Maximum size: length 72mm, height 25mm, width 35mm, weight 114g.
- ESC: 25 to 30A – with BEC 5V or higher.
- Cyclic servos: Standard Sub MICRO size servo speed: =>0.06 sec/60 at 6V.
- Rudder servo: Standard MICRO size servo – speed =>0.06 sec/60 at 6V – a specific rudder servo is suggested for best tail authority.
- FBL system: The Oxy 2 was designed around the U-Ikon / U-Brain and Neo V-Bar Systems. But many other smaller size FBL systems can be used, depending on your personal choice. Max inner Frame dimension 26mm.
- Main blade: The Oxy 2 can fly with plastic or CF main blades from 190 to 210mm. Our testing was with Lynx 190mm Carbon Plastic main blades, and Zeal 210mm main blades. The Oxy 2 main grips use M2 clamp screw and have a 3.2 mm root.
- Tail blades: The Oxy 2 uses our own OEM tail blades, either 38 or 41 mm (included with the kit). They use a M1.6 clamp screw and 3 root.

We offer 38 and 41 mm tail blades to suit different head speeds. Use 41 mm tail blades when your head speed is lower than 4500rpm and 38mm with higher head speeds.

Vertical Fin Assembly
(Box 1/Bag 1)

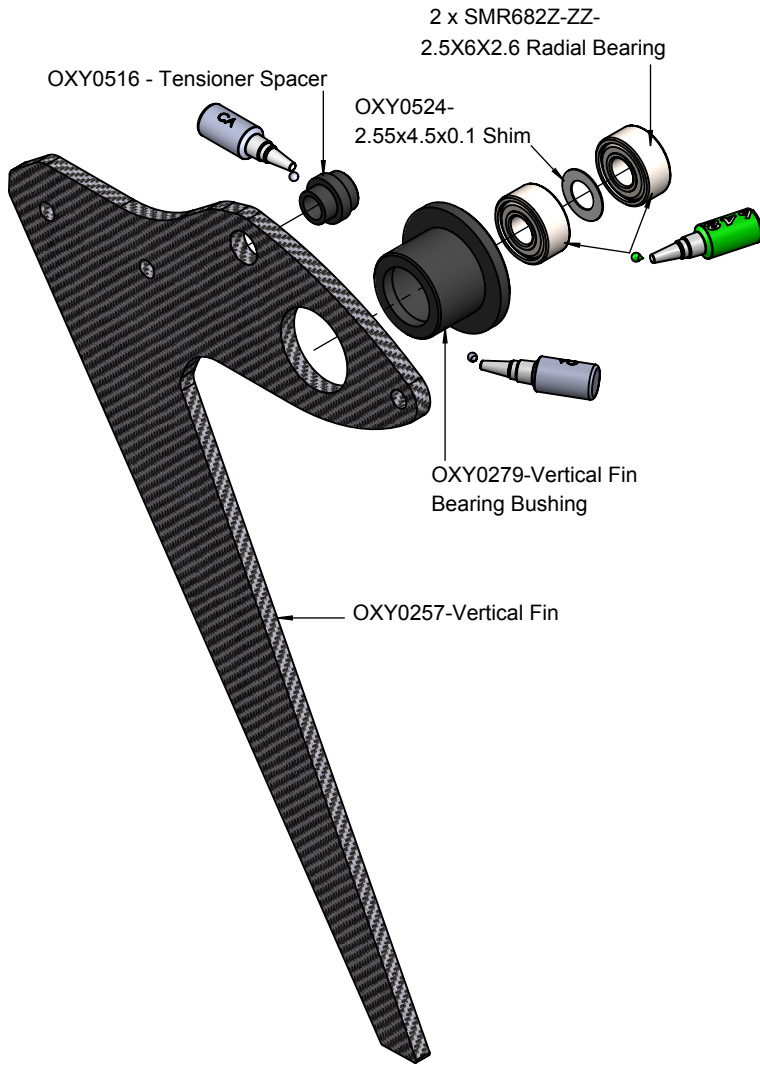

⚠ Important Note:
This part, for tuning reasons,
comes factory pre assembled,
it ready to use

Tail Case Assembly
(Box 1/Bag 2)

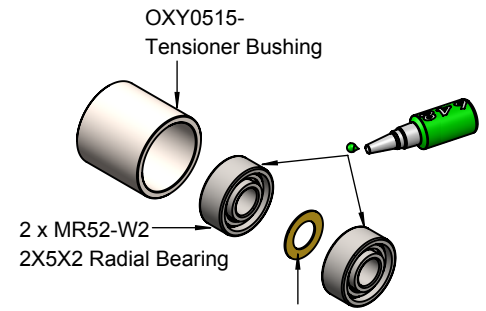

⚠ Important Note:
This part, for tuning reasons,
comes factory pre assembled,
it ready to use

Tail Rotor Assembly
(Box 1/Bag 3)

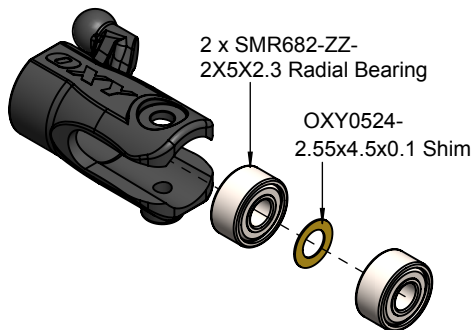

⚠ Important Note:
This part comes pre assembled
WITHOUT thread lock. It MUST be
re-assembled with thread lock as shown.

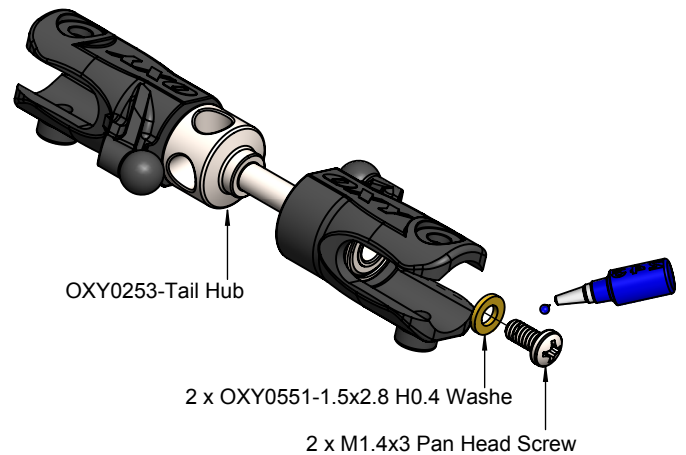

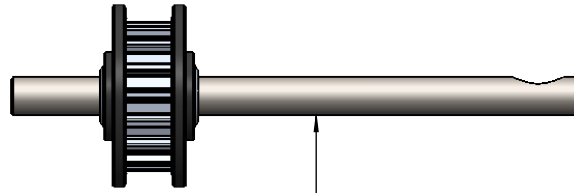
Tail Shaft Assembly*(Box 1/Bag 4)*

Tail Shaft 16T

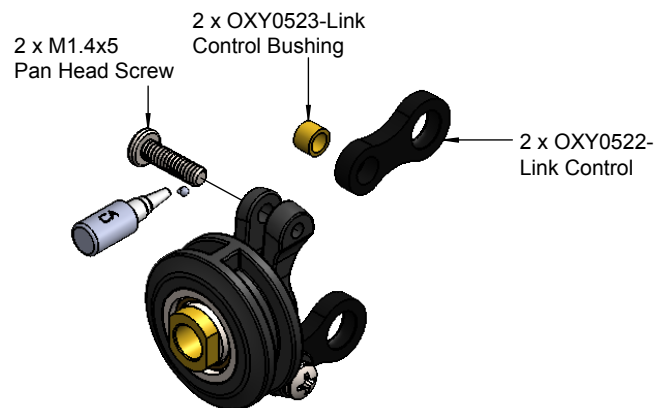

Important Note:
This part, for tuning reasons,
comes factory pre assembled,
it ready to use.

Tail Pitch Slider Assembly*(Box 1/Bag 5)*

Important Note:
This part comes pre assembled,
WITHOUT THREAD lock. Follow
the instruction for final assembly.

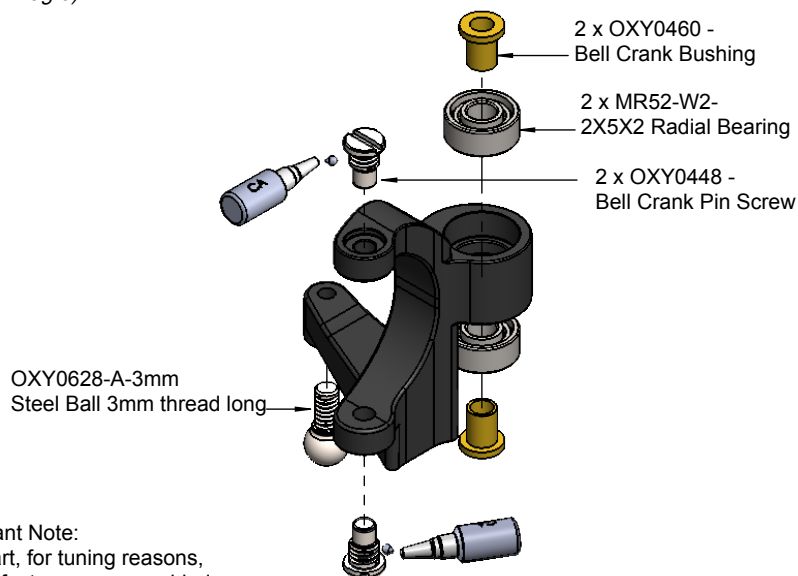

Do not over tighten
Pan Head Screw 2XM1.4x5

Tail Belt Crank Assembly*(Box 1/Bag 6)*

Important Note:
This part, for tuning reasons,
comes factory pre assembled,
it ready to use.

Carbon Fiber Tail Push Rod Assembly
(Box 3/Bag 1)

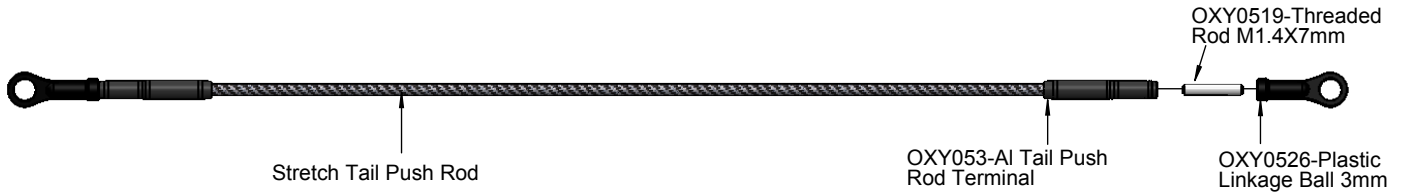

Important Note:
This part, for tuning reasons, comes factory pre assembly, it ready to use.

Tail Push Rod Guide Assembly
(Box 3/Bag 1)

Step 1:

Warning: Note: to install this pin screw rotate counter clock wire.

2 x OXY0539-Pin Screw

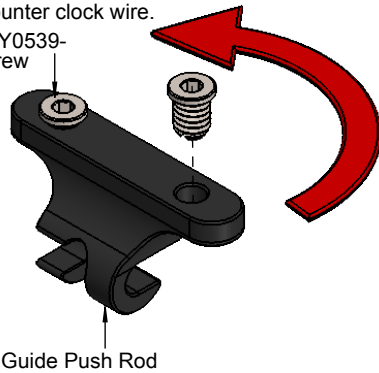

Step 2:

Warning: Note: Install the Pin Screw and leave a gap as shown.

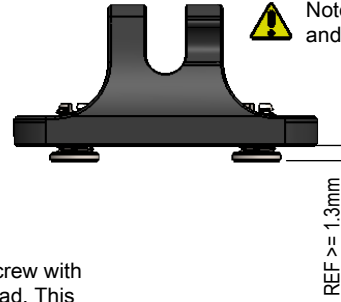

Warning: Note Pin Screw Thread: Oxy designed the Pin Screw with a counter clockwise thread. This will help on the final locking operation. Be careful to follow our instructions to get a perfect assembly.

Step 3:

Push the part inside the boom sockets as shown.

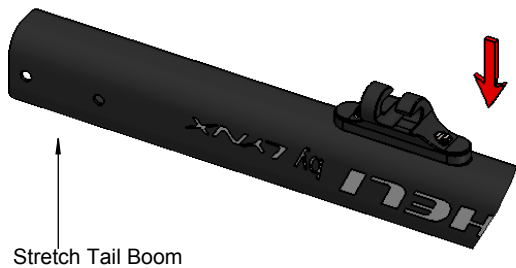

Step 4:

Slide the parts as shown

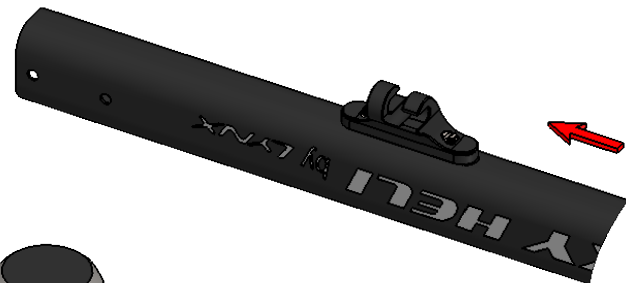

Step 5:

In order to lock the tail push rod support, use a Flat Screw Driver and turn clockwise. Do not over tighten.

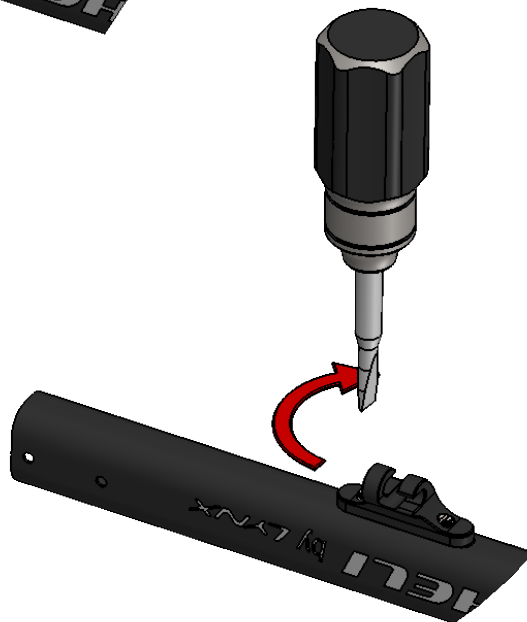

Warning: Important Note: This part, for tuning reasons, comes factory pre assembly, it ready to use.

Tail Assembly Step 1

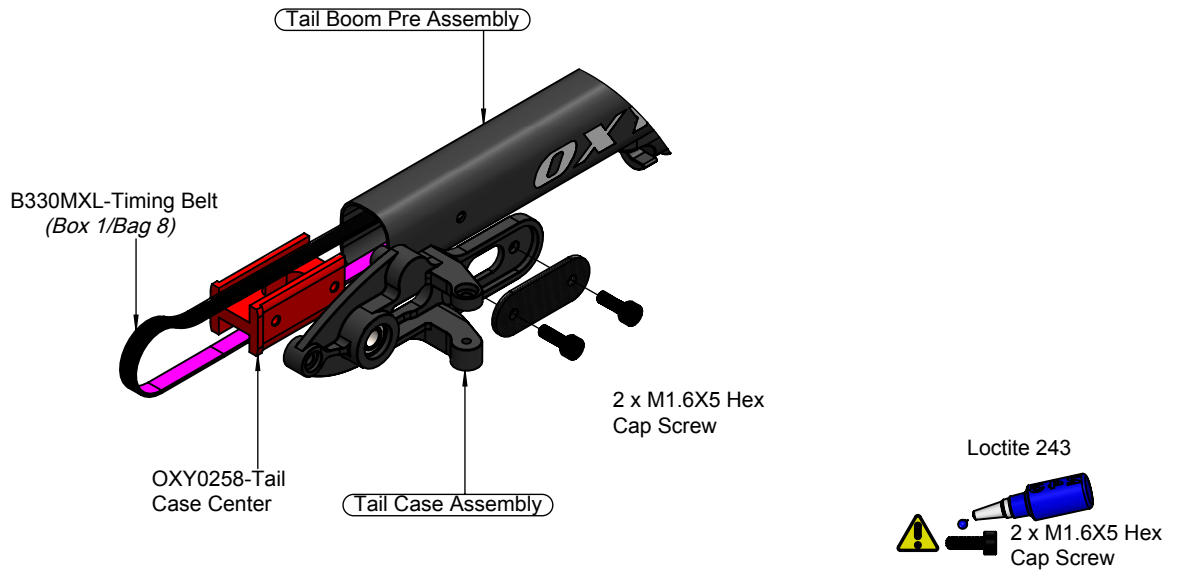

Tail Assembly Step 2

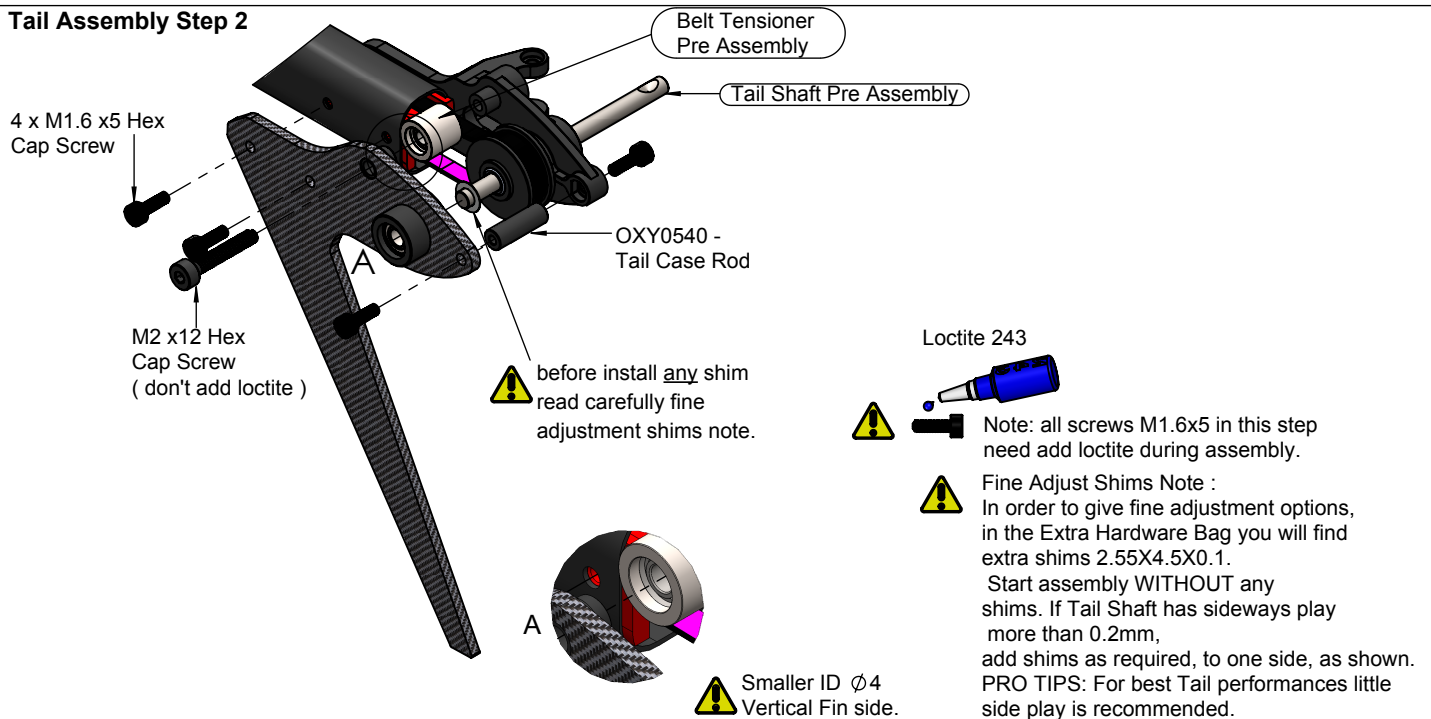

Tail Assembly Step 3

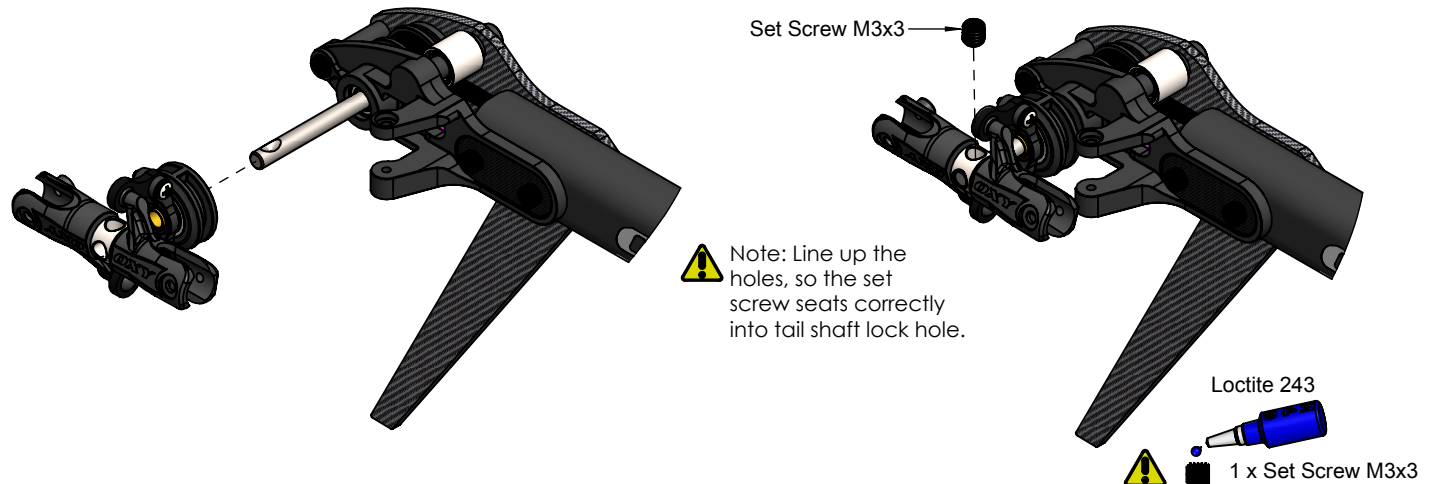

Tail Assembly Step 4

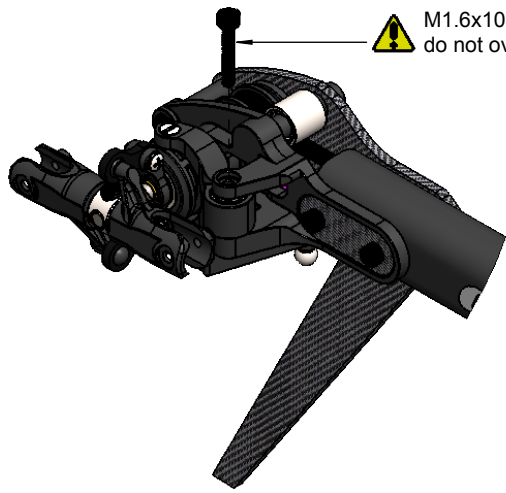

 M1.6x10 Hex Cap Screw, do not over tighten the Screw

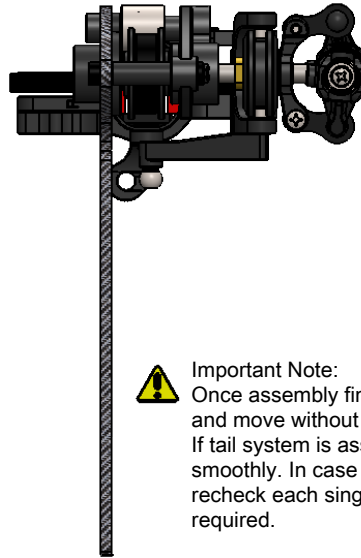

 Important Note:
Once assembly finish, check if the system can slide and move without friction.
If tail system is assembled correctly, it should move smoothly. In case of friction or extra play, recheck each single component and re-assembly as required.

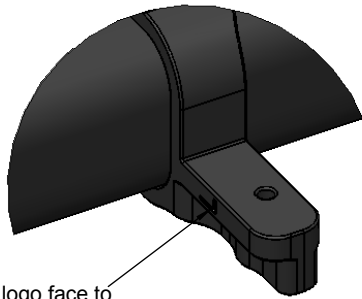

L logo face to Main Frame

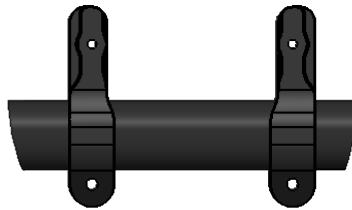

Bottom View

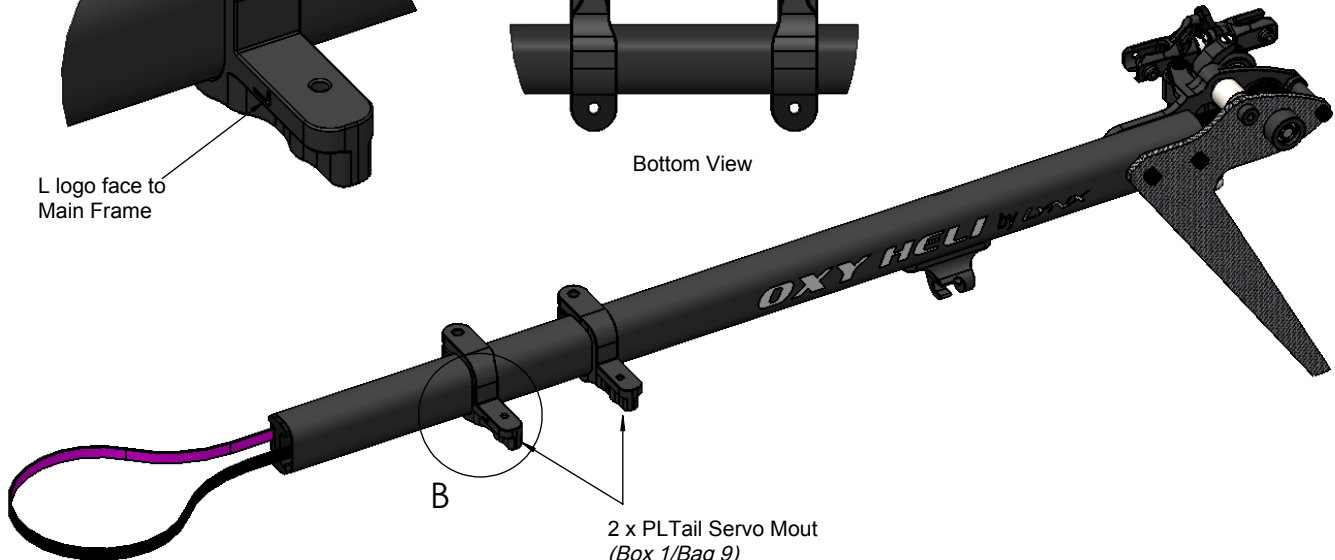

B

2 x PLTail Servo Mount
(Box 1/Bag 9)
Note: don't install any screw

 TAIL BELT ASSEMBLY AND DIRECTION CHECK:
In order to check correct belt install, move belt position A CW and the position B must rotate CW.
Before go forward on Tail Assembly check carefully if Belt is installed per need.
Belt MUST move without any friction.

B

A

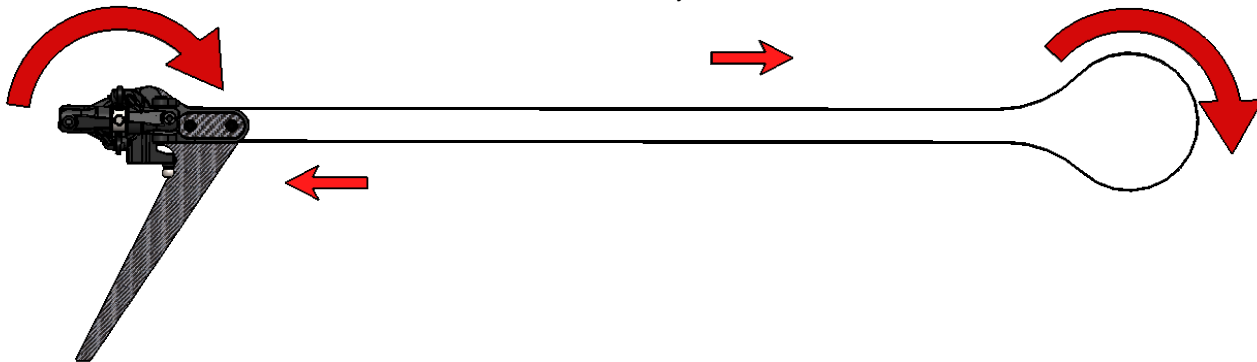

Tail Assembly Step 5

Step 5-1:
Tail belt is showed straight coming out,
form tail boom. Be careful to
check the belt if not twisted inside the boom.
Use a flashlight to check inside the boom.
Rotate the belt 90 degrees CCW as shown.



90° CCW Rotation.

Step 5-2:
Hold carefully Tail Belt as showed and insert
Front Boom Insert.

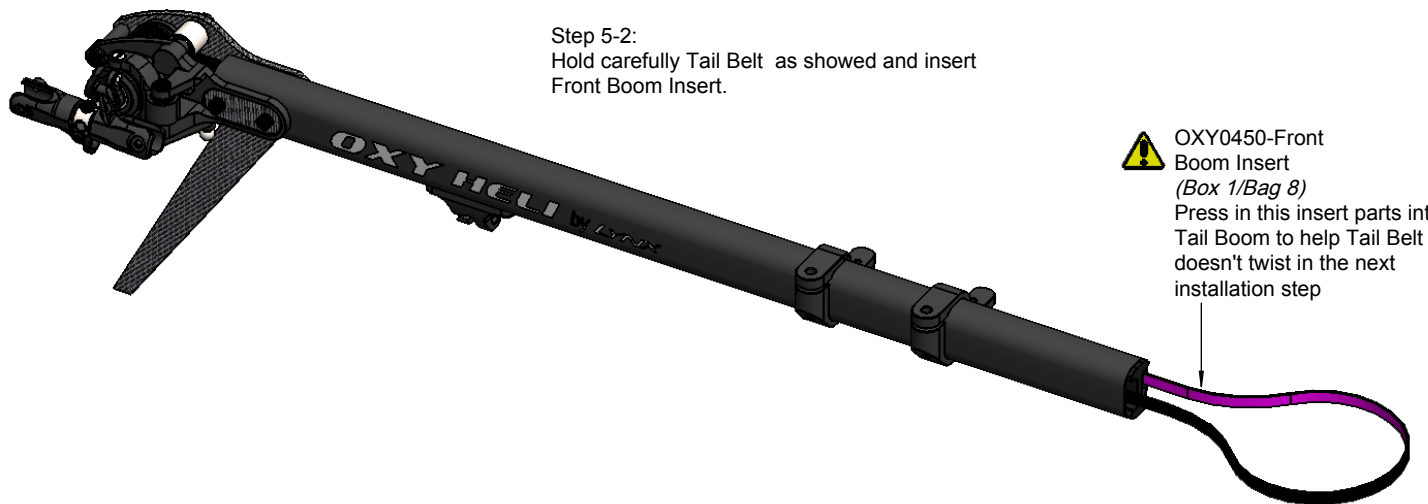

 OXY0450-Front
Boom Insert
(Box 1/Bag 8)
Press in this insert parts into
Tail Boom to help Tail Belt
doesn't twist in the next
installation step

Step 5-3:
Final Tail Belt Direction Check:
Pull Tail Belt (as shown) and check the tail hub rotates
in the direction shown. If the Tail Rotor rotates
in the wrong direction, go back to the previous
instructions and double check your assembly.



Pull Tail Belt here

Boom Clamp Assembly

(Box 2/Bag 1)

Pulley Guide Belt Assembly

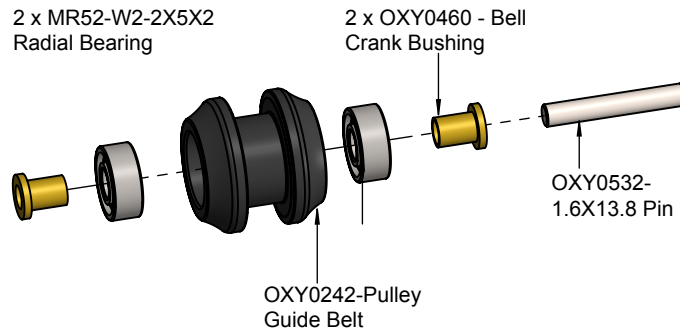

⚠ Important Note:
this part, for tuning reasons,
comes factory pre assembled,
it ready to use

2 x Pulley Guide Belt Assembly

Install the Pins into the Pulley Guides and press completely into the Tail Boom Clamp Socket Lips.

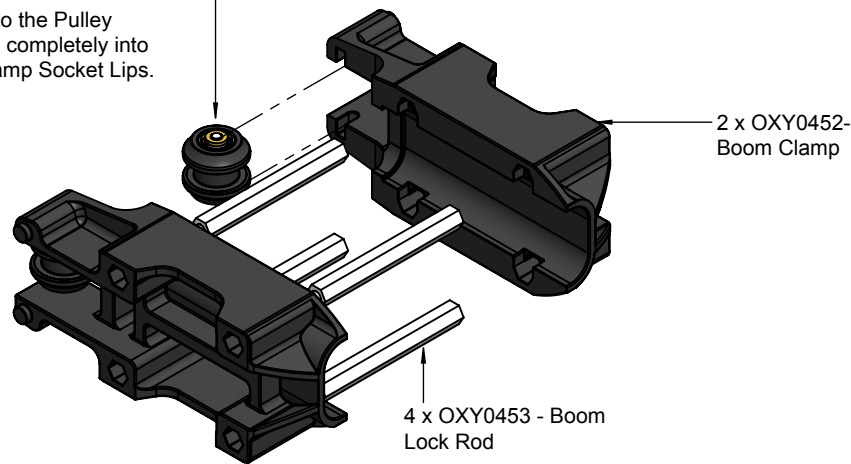

Upper Main Shaft Bearing Block Assembly

(Box 1-1/Bag 1)

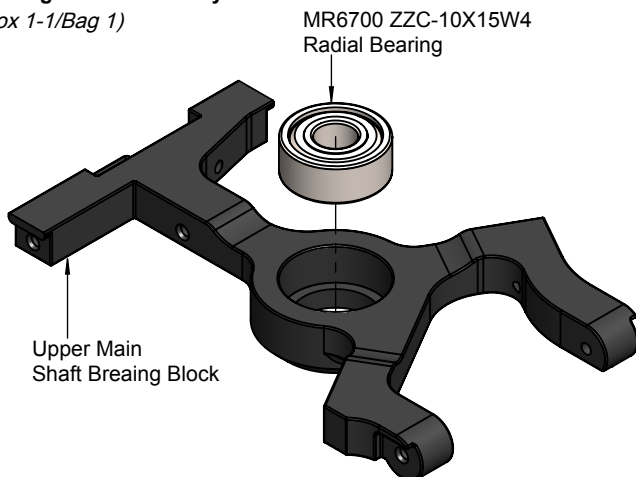

Lower Main Shaft Bearing Block Assembly

(Box 1-1/Bag 2)

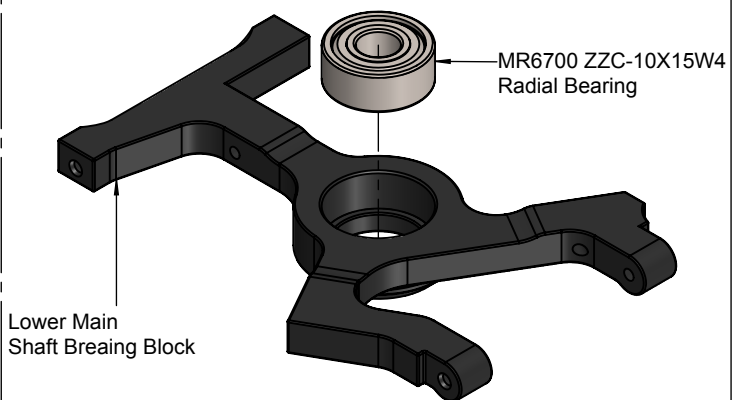

Canopy Mount Assembly

(Box 1-1/Bag 3)

Left Canopy Mount Assembly

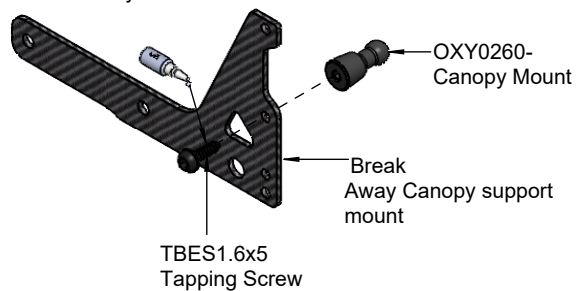

Right Canopy Mount Assembly

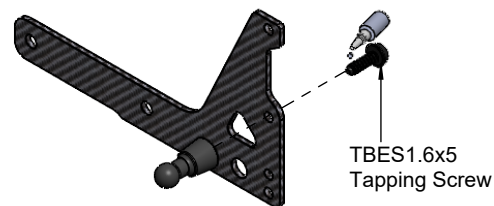
**Motor Pinion Installation**

- ⚠ Note:** Output Motor Shaft preparation: because OXY2 pinion have bonding assembly follow below step for best results.
- 1- Sand Paper output shaft.
 - 2- Use bonding compound (Loctite 648 or Lynx LX5648). Don't use STD lock thread.
 - 3- After Install wait at least 10h before fly.

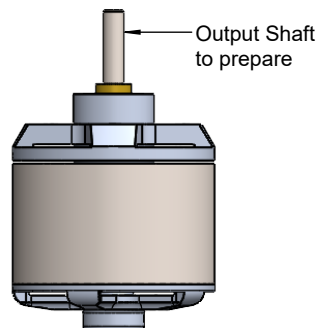
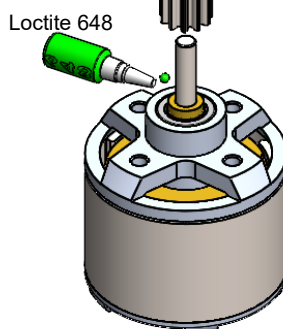
Kit Pinion
11T ID \varnothing 2mm
(Box 1-1/Bag 4)

- ⚠** Use bonding compound Loctite 648 or LX5648, don't use standard lock thread

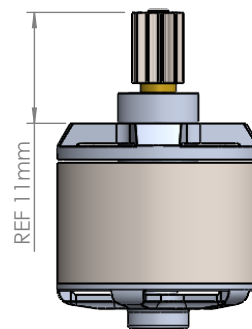

- ⚠** after install wait until 10h before fly

Motor Installation

- ⚠** OXY2 support two size of motor fitting (13mm/M2 and 19mm/M2.5), choose the correct holes dependig on the used Motor.
- ⚠** Use Hex Cap Screw M2x5 for 13mm holes
Use Button Head Screw M2.5x5 for 19mm holes

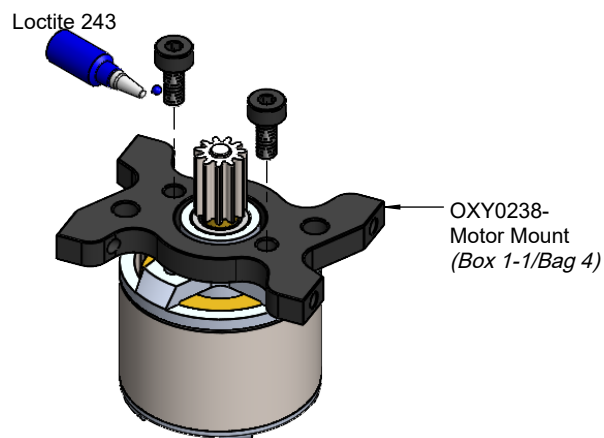
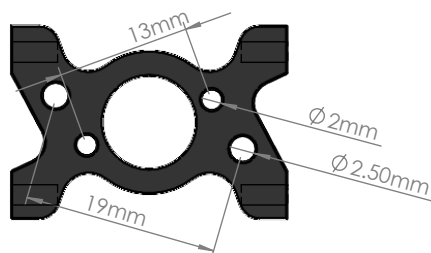

Main Frame Assembly Step 1

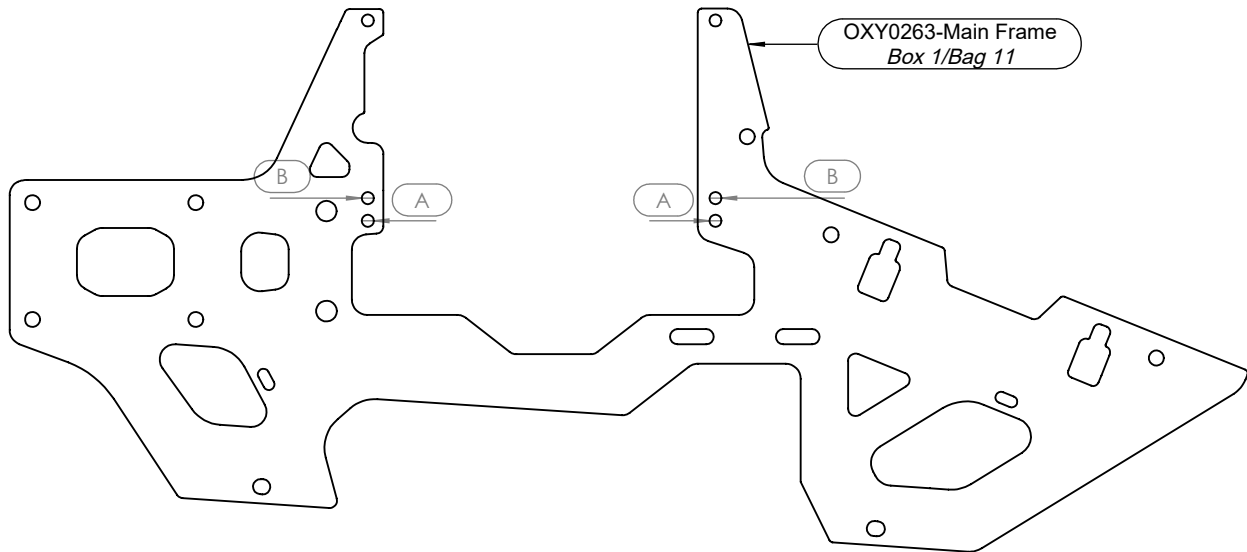

OXY0263-Main Frame
Box 1/Bag 11

⚠ OXY2 support two kind of Servo dimension options.
Lower Bearing Block can be installed in two Frame position.
Follow note for Servo type A or B install.

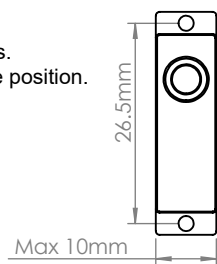

Servo type A
use Frame holes A position

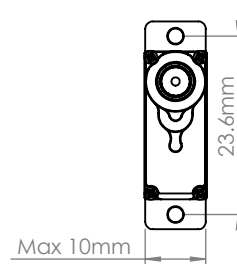

Servo type B
use Frame holes B position

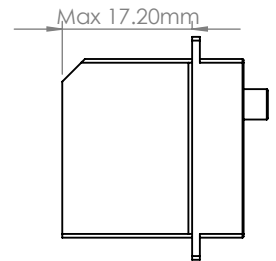

Maximum length for
both cyclic Servo

Main Frame Assembly Step 1

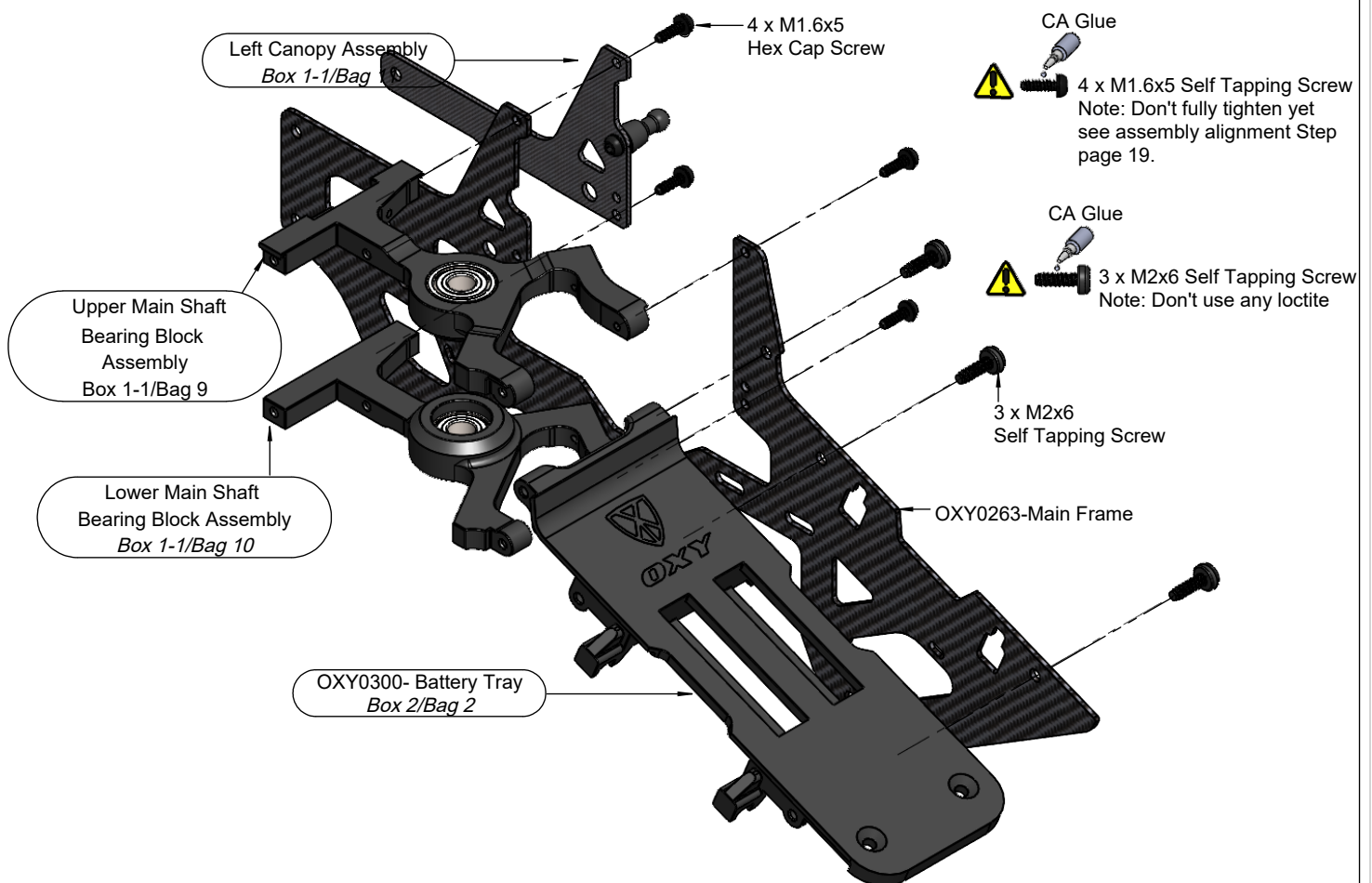

Left Canopy Assembly
Box 1-1/Bag 1

4 x M1.6x5
Hex Cap Screw

CA Glue



4 x M1.6x5 Self Tapping Screw
Note: Don't fully tighten yet
see assembly alignment Step
page 19.

CA Glue



3 x M2x6 Self Tapping Screw
Note: Don't use any loctite

Upper Main Shaft
Bearing Block
Assembly
Box 1-1/Bag 9

Lower Main Shaft
Bearing Block Assembly
Box 1-1/Bag 10

3 x M2x6
Self Tapping Screw

OXY0263-Main Frame

OXY0300- Battery Tray
Box 2/Bag 2

Main Frame Assembly Step 2

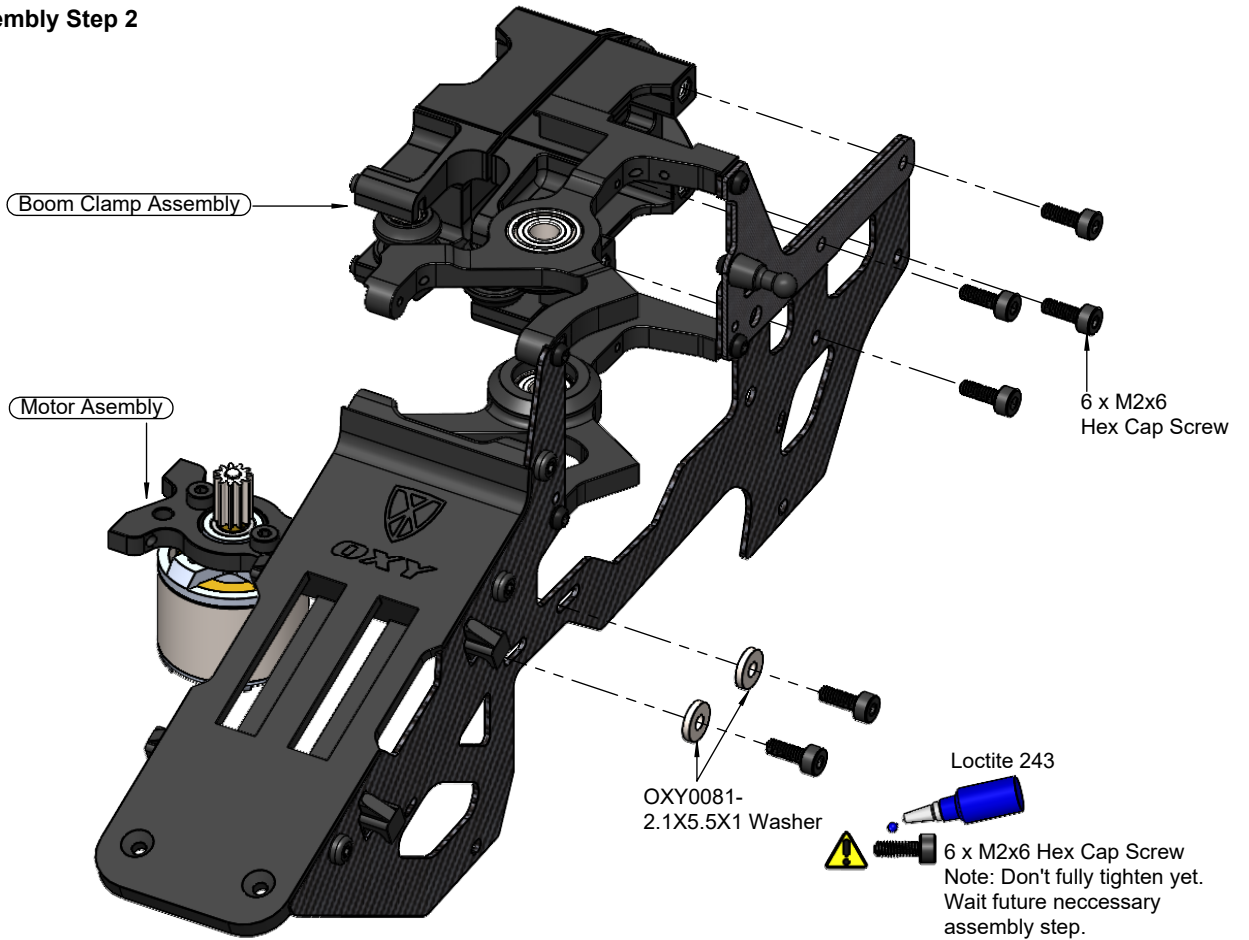

Main Frame Assembly Step 3

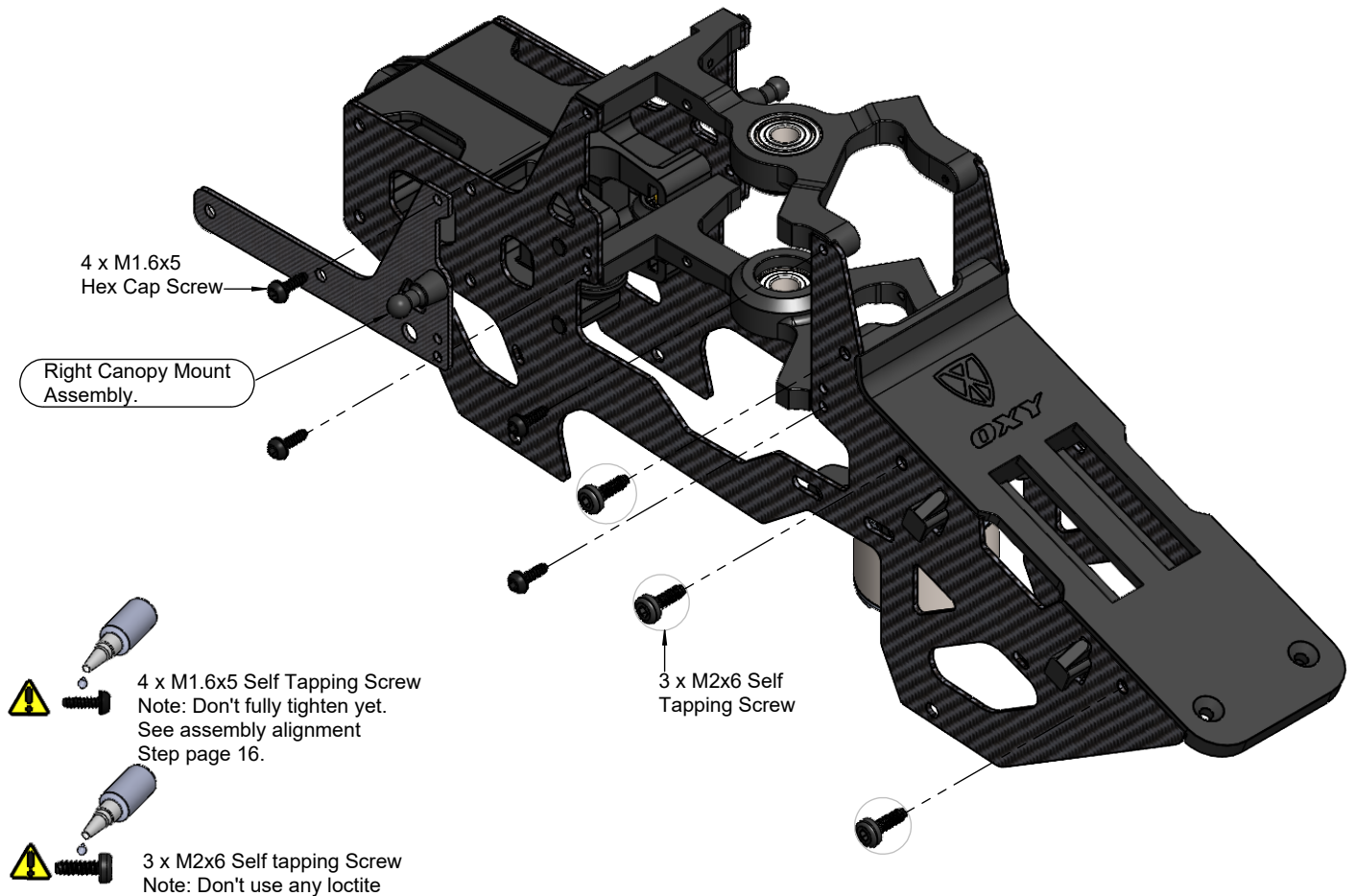

Main Frame Assembly Step 4

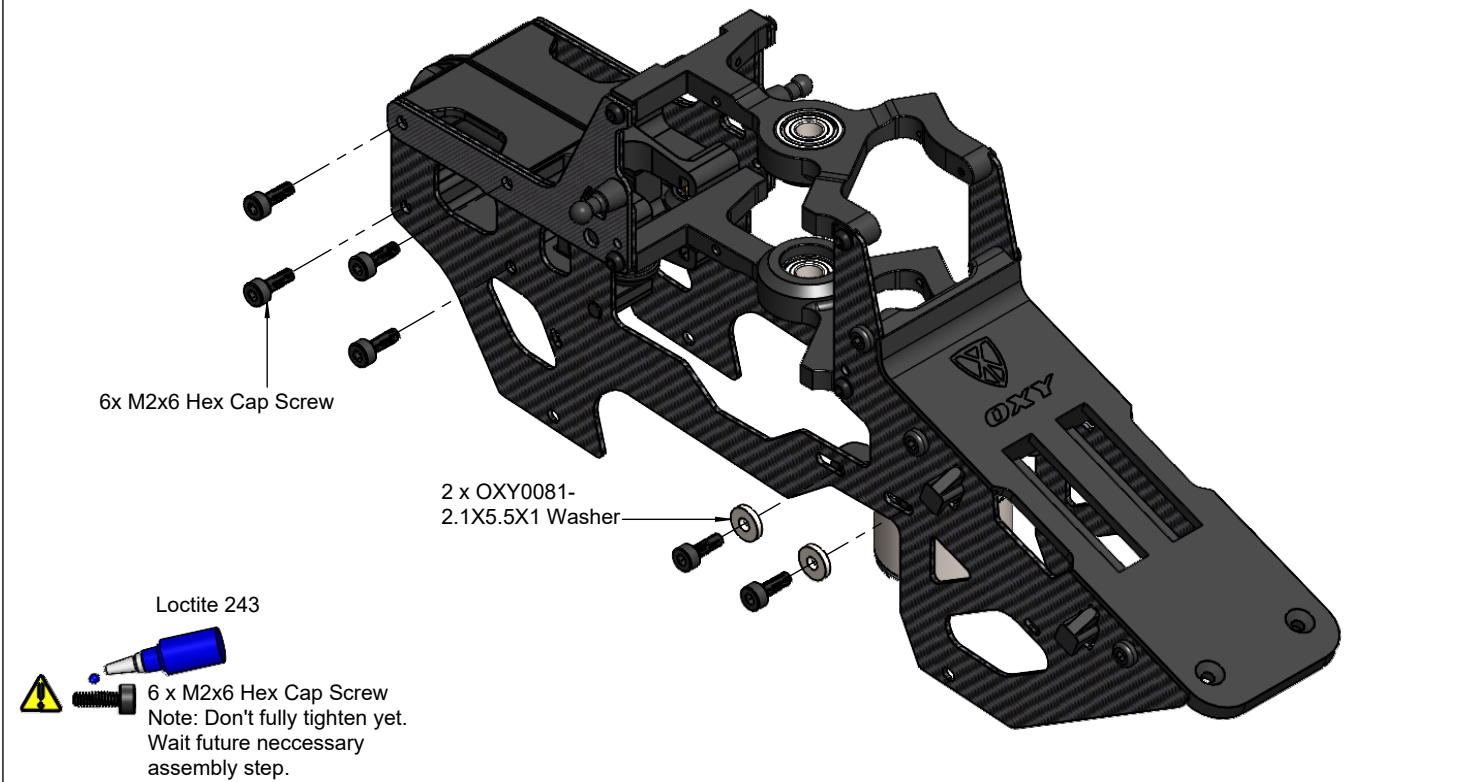

Main Frame Assembly Step 5

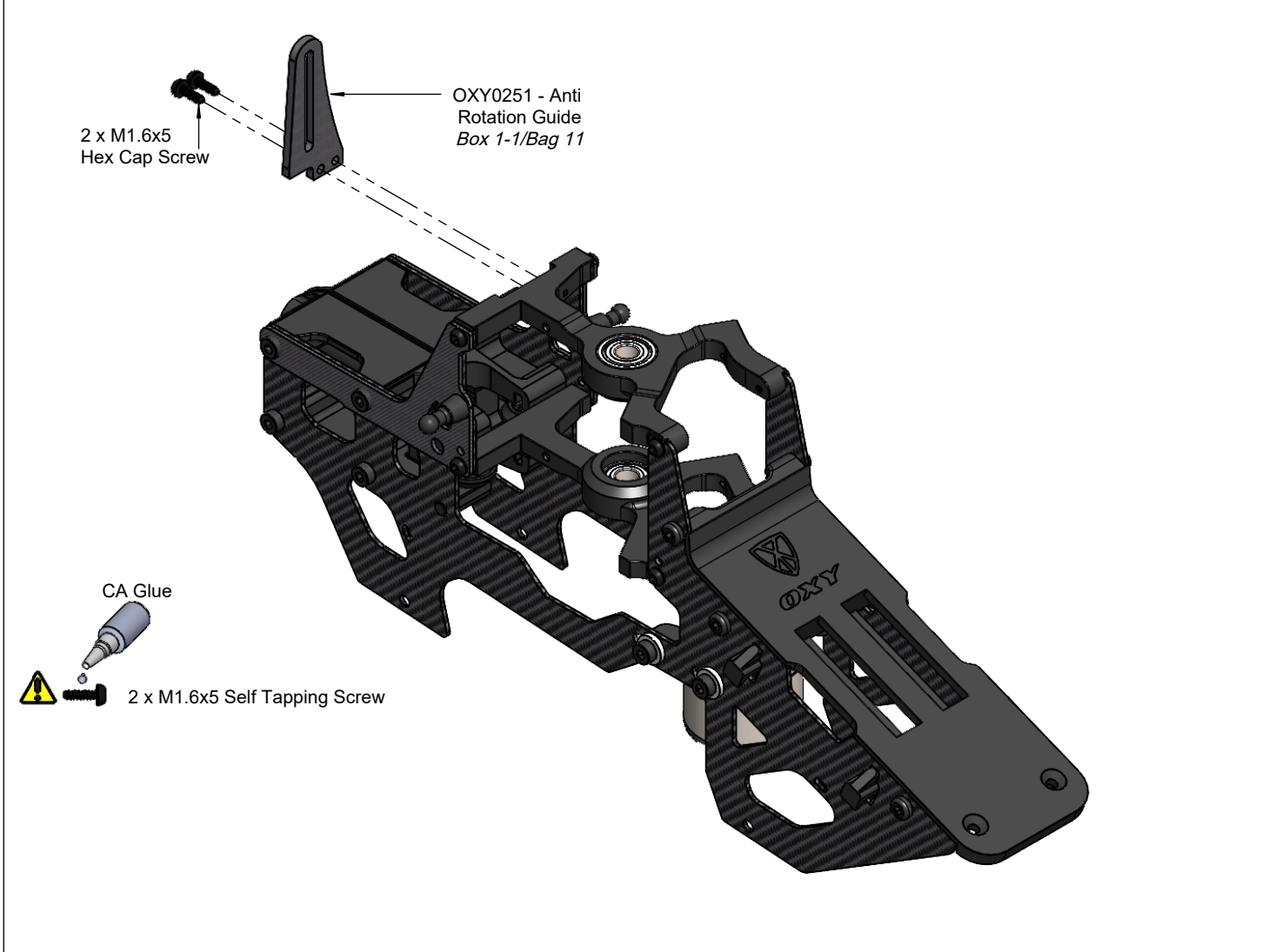

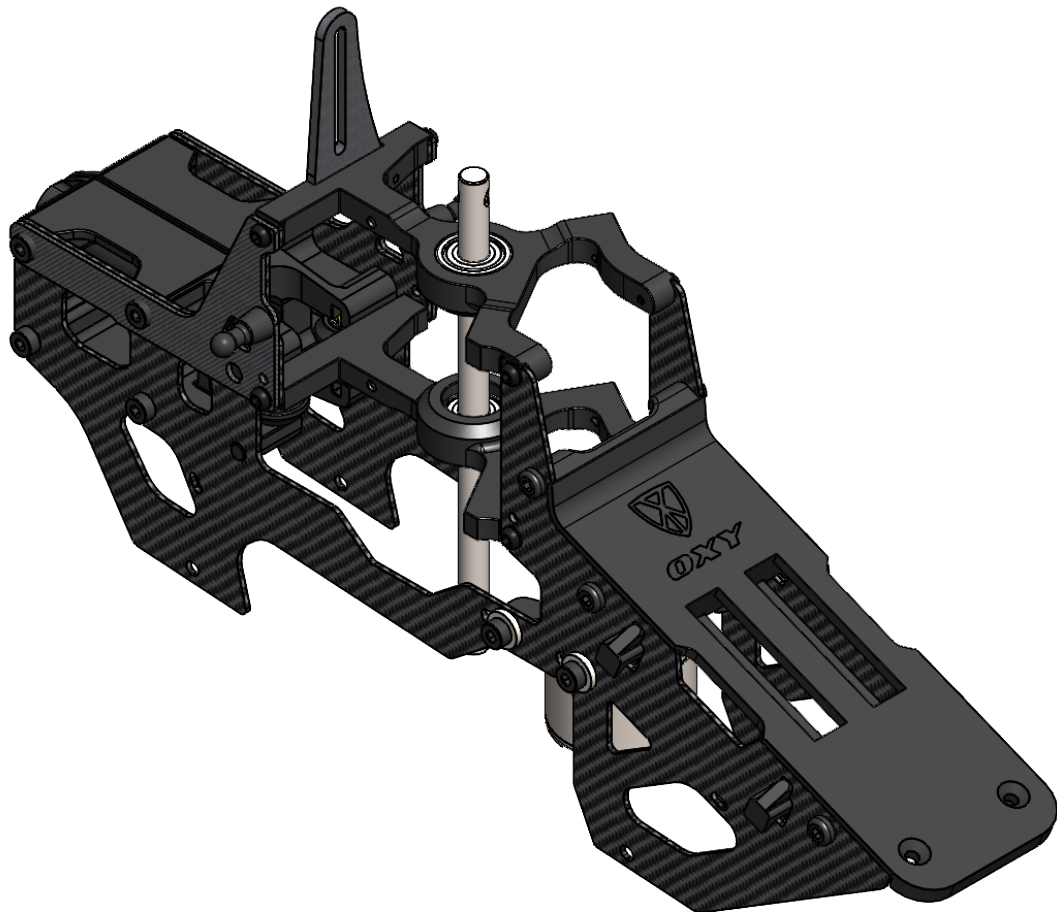
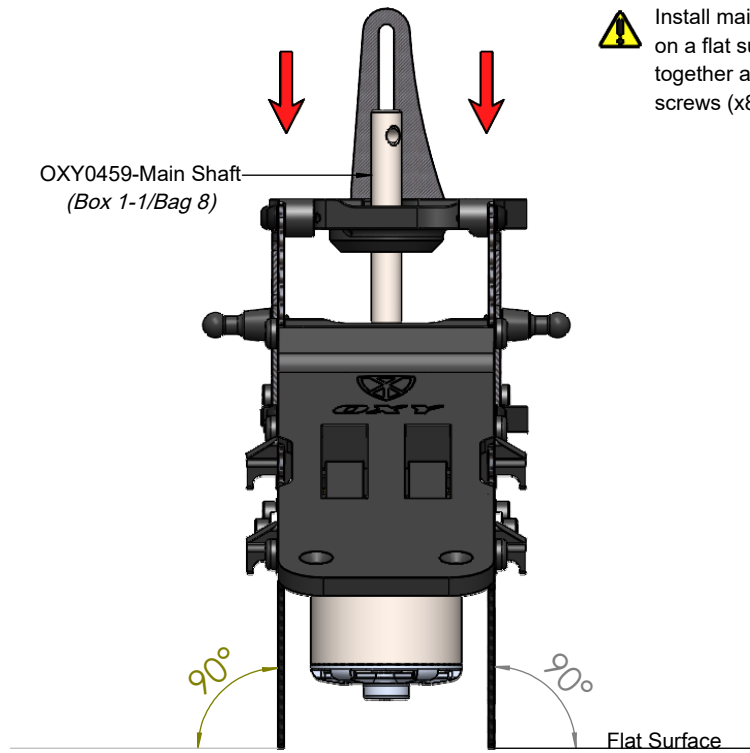

Tail System And Main Gear Installation

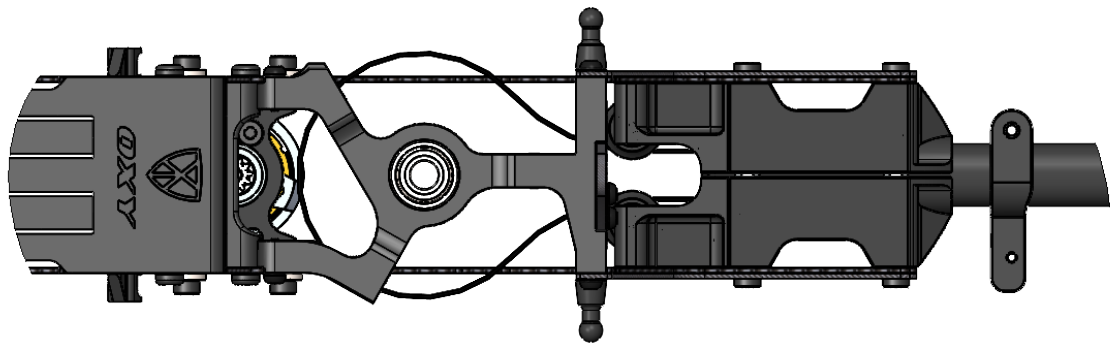
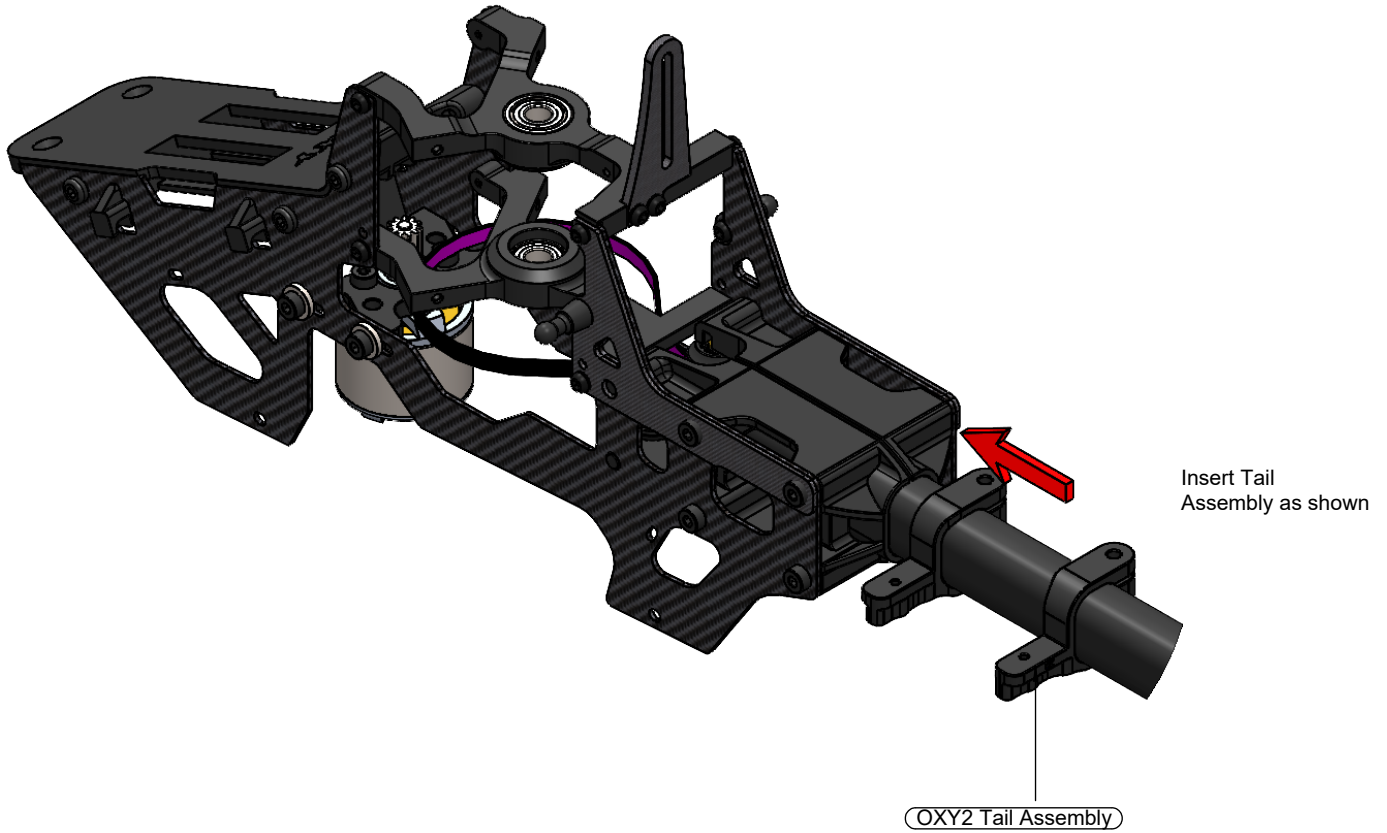

Before next assembly step check carefully Tail Belt assembly position as shown.

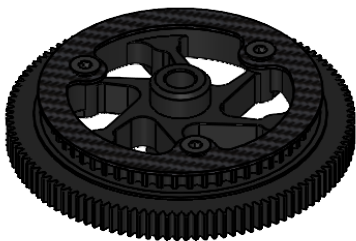

Main Gear 113T-55T pulley Assembly (Box 2/Bag 3)

! Important Note:
The Main Gear come factory pre assembled. It is ready to use.

! OXY2 support two kind of servo dimension, use specific main gear bushing spacer for Servo type B.

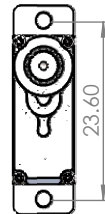

Servo Type B

OXY0247 - Main Gear Bushing

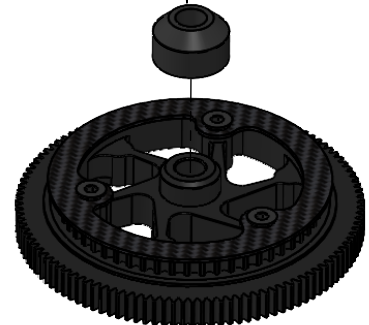

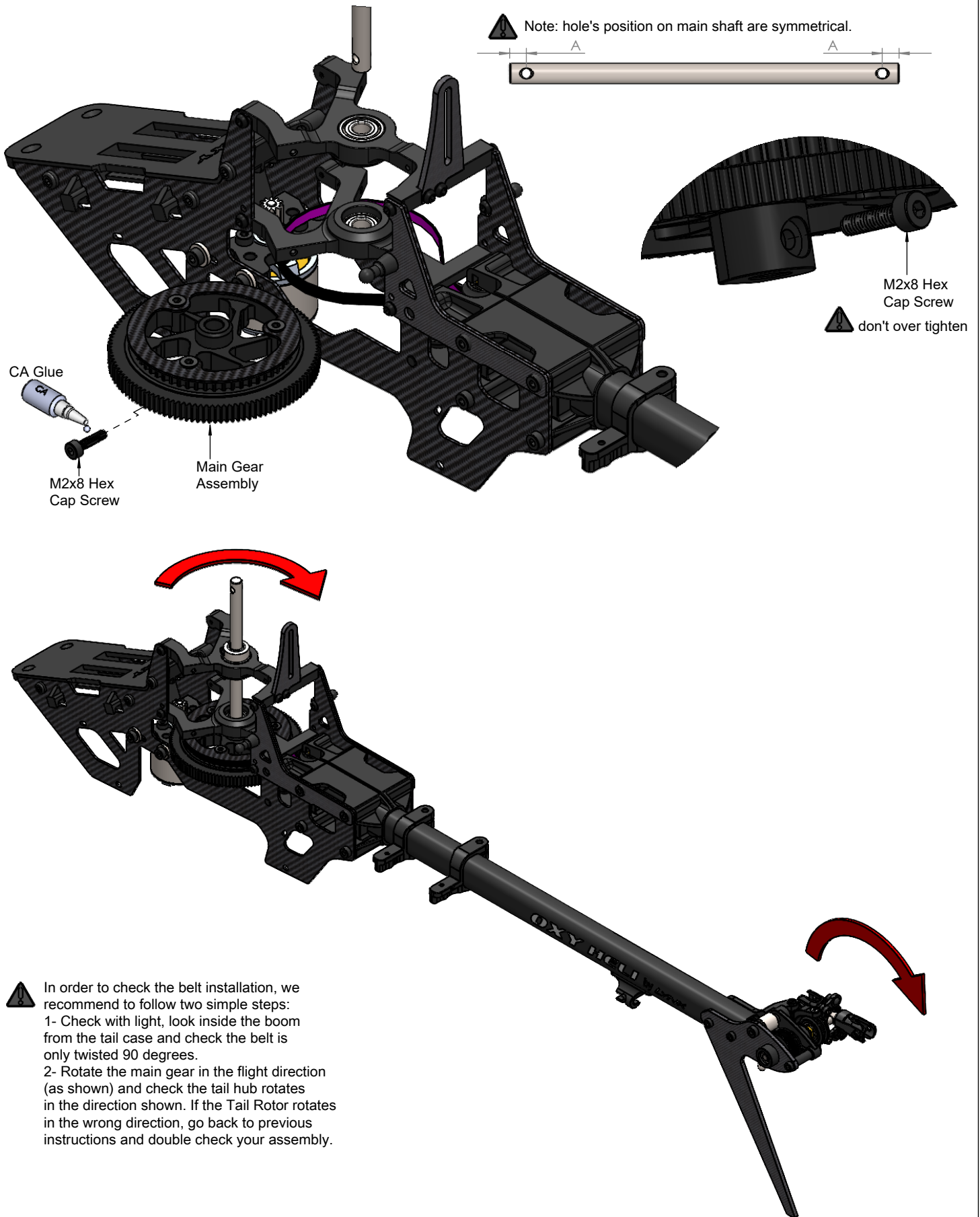

Main Shaft Collar and Tail Belt tensioning.

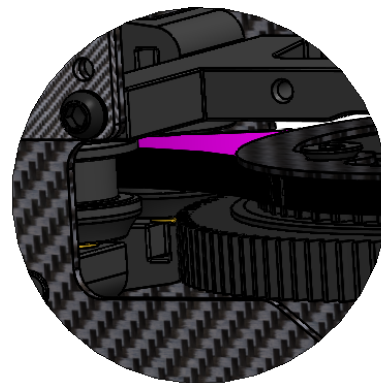
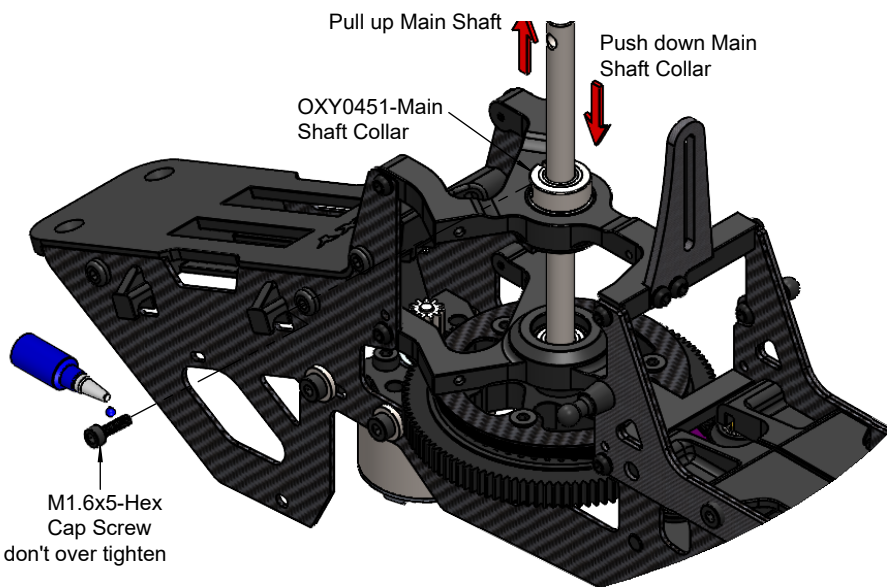

Tail Belt Pulley Note:
 Before tensioning Tail Belt, check if correctly positioned in both Belt Pulleys.

M1.6x5-Hex Cap Screw
 don't over tighten

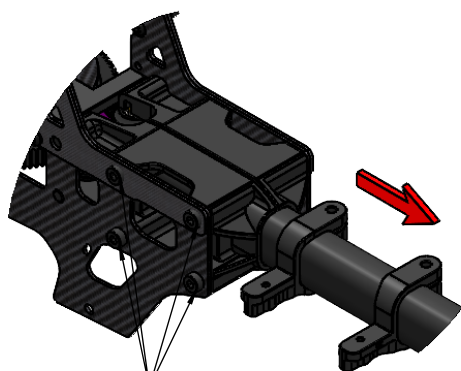

8 x M2x6 Hex Cap Screw

- Be sure the boom is assembled and installed correctly.
- Loosen the tail boom by loosening the eight M2x6 Hex Cap Screws.
- Adjust the Belt tension by pulling on the Tail Boom.
- Tighten the eight M2x6 Hex Cap Screws.
- The belt must have good tension. We suggest re-checking after a few flights. We suggest to check belt tension often, before each flying session.
- If spool up get difficult, may Tail Belt is over tight, recheck and eventually loose Belt tension little bit
- If the belt is often loose, you should check the lock system or belt integrity.
- Tests show that a hard 3D pilot can perform over 400 flights before the belt will fail. We recommend replacing the Tail Belt after 300 flights, even if it does not show wear, to avoid it breaking unexpectedly in flight.
- After a crash, spend some time checking Belt integrity and replace if any teeth are missing.

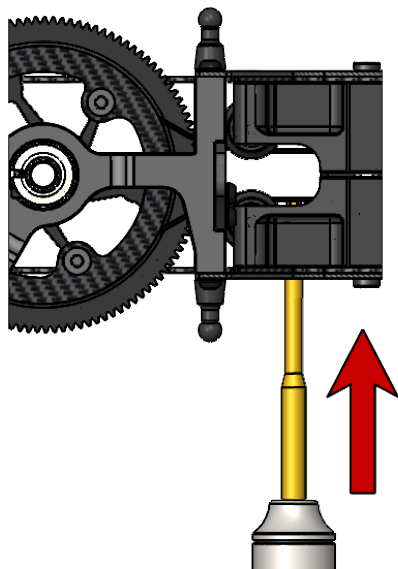

- Use a Screw Driver to check Belt Tension (suggested max deflection is 1mm)
- Note: We recommend a tight Belt tension.
- If spool up get difficult, may Tail Belt is over tight, recheck and eventually loose Belt tension little bit
- Check the Belt tension again after the first 2 flights.
- With a new Tail Belt, when the head is rotated slowly, it is normal to hear a tooth sound as the belt engages with the Main Pulley. This sound is normal and will disappear after a few flights and the necessary "break-in".

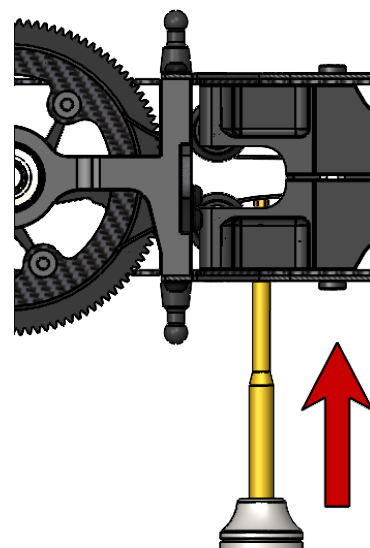

Main Grip Assembly
(Box 1-1/Bag 5)

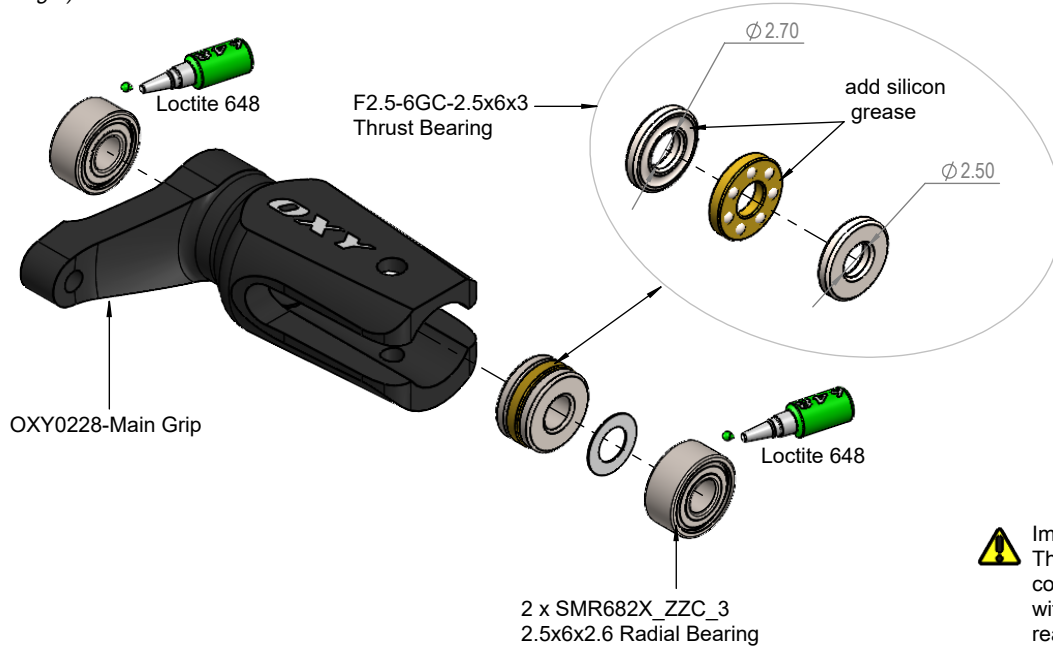

Important Note:
This part, for tuning reasons, comes factory pre assembled with grease and loctite. It is ready to use.

DFC Arm Assembly
(Box 1-1/Bag 5)

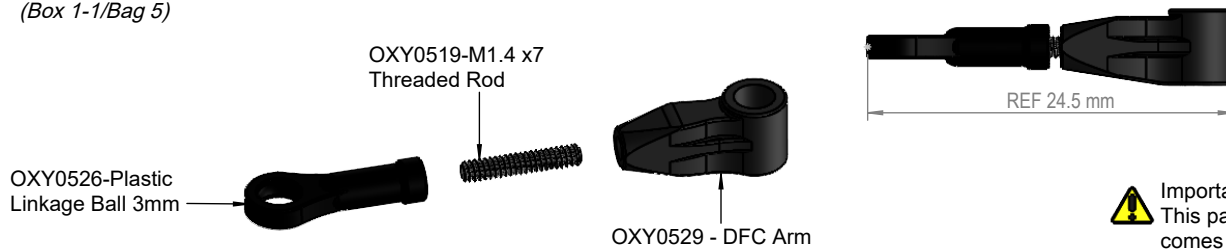

Important Note:
This part, for tuning reasons, comes factory pre assembled.

Main Rotor Assembly
(Box 1-1/Bag 5)

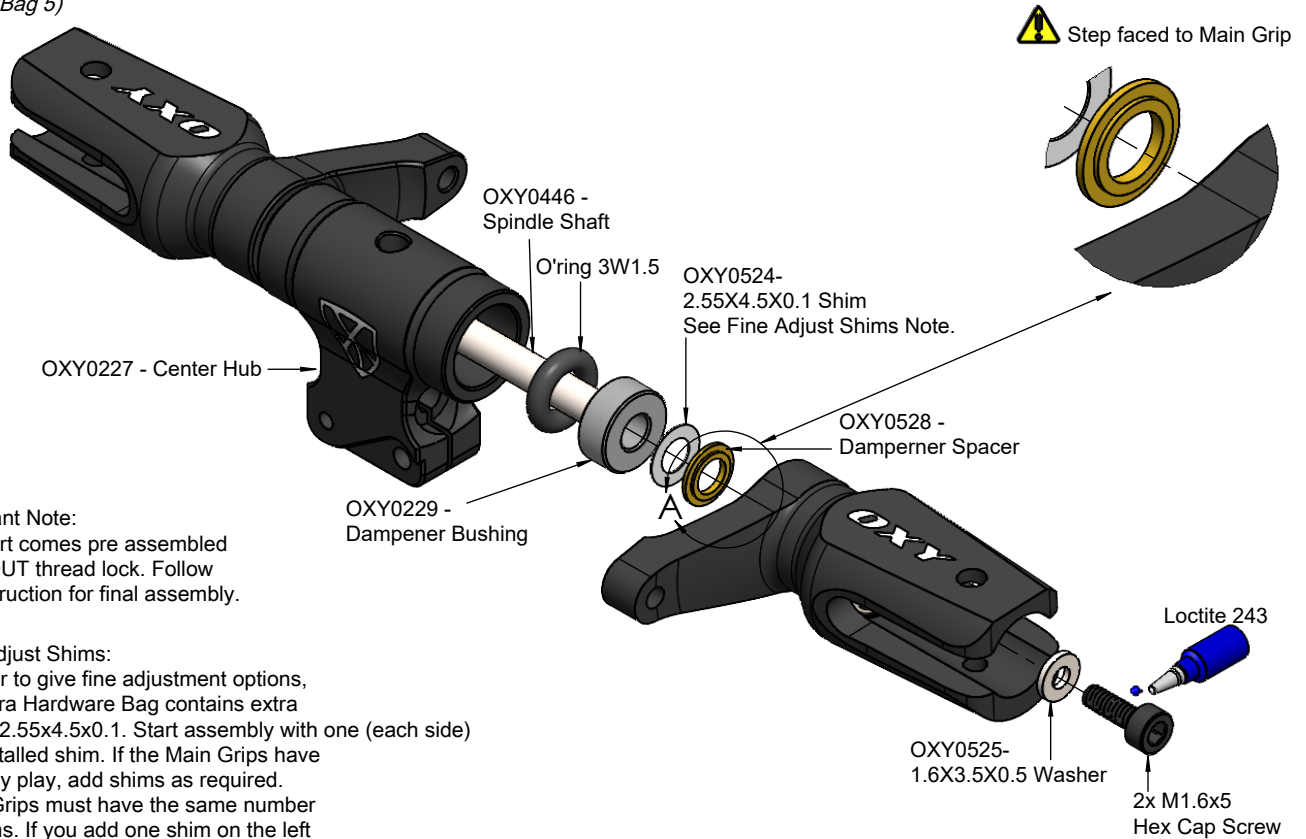



Important Note:
This part comes pre assembled WITHOUT thread lock. Follow the instruction for final assembly.

Fine Adjust Shims:
In order to give fine adjustment options, the extra Hardware Bag contains extra Shims 2.55x4.5x0.1. Start assembly with one (each side) pre installed shim. If the Main Grips have sideway play, add shims as required. Each Grips must have the same number of shims. If you add one shim on the left side, you need to also add one shim on the right side.

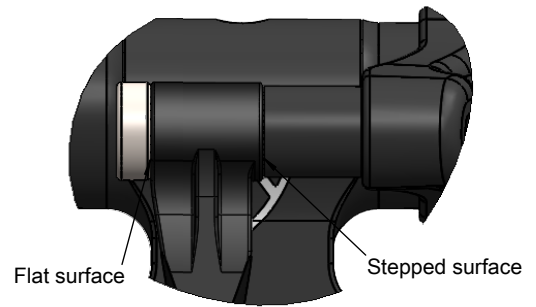
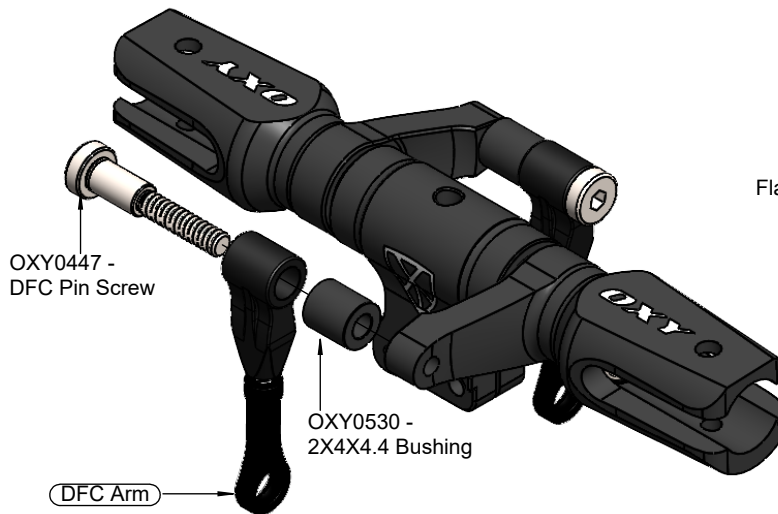
Main Rotor Assembly
(Box 1-1/Bag 5)



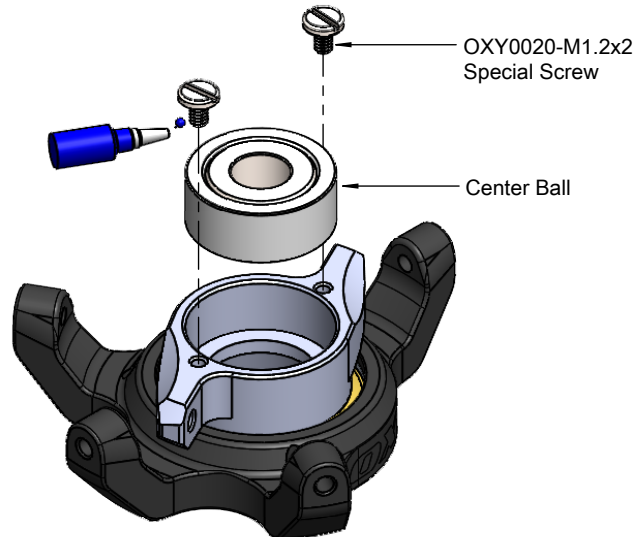

-  DFC Arm are not symmetrical. Flat surface faced to Screw. Step faced to Main Grip.
-  Important Note: This part comes pre assembled WITHOUT thread lock. Follow the instruction for final assembly.
-  Once you finish assembly, ensure the DFC Arms can rotate without friction. If the DFC Arms are assembled correctly, rotation should be smooth and without friction. In case of any friction, recheck each component and re-assembly as necessary.

Swash Plate Assembly
(Box 1-1/Bag 6)

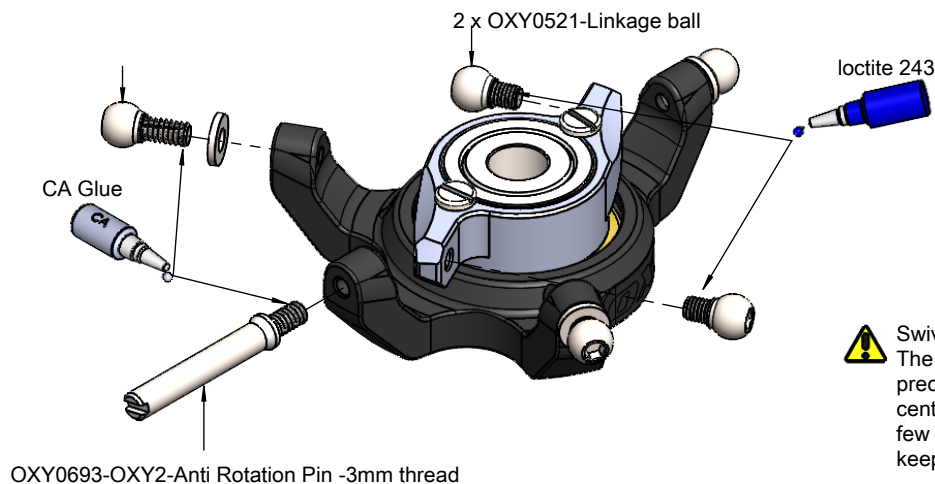

-  Important Note: this part, for tuning reasons, comes factory pre assembled, it ready to use.



-  Swivel Ball Note: The Swivel Ball is pre-assembled with a precise fitting. When new, the Swash Plate center ball will have a little friction. After a few flights and "break-in" it will come smooth, keeping the best precision without play.

Main Rotor Assembly step 1

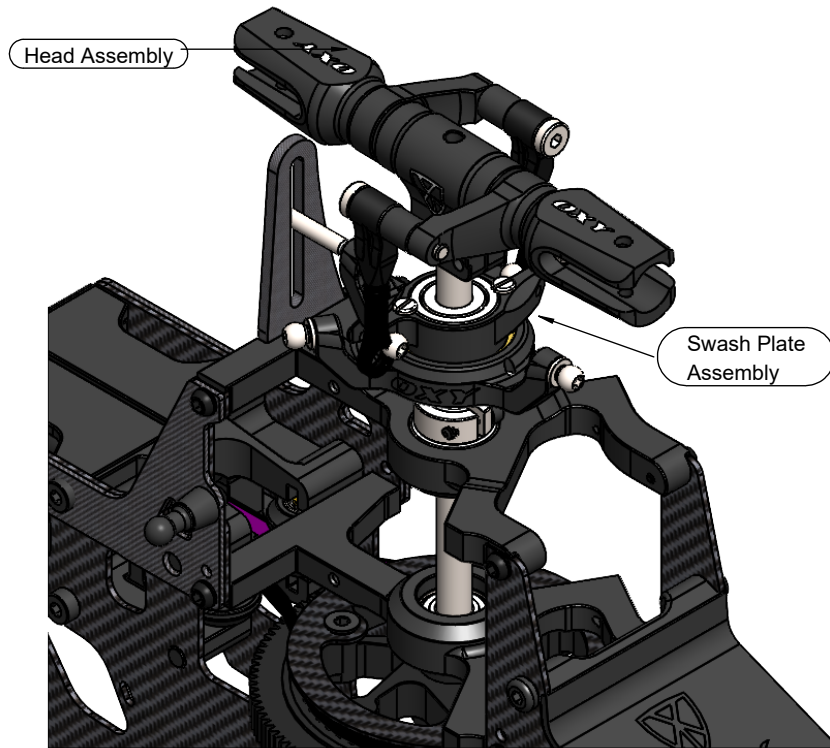

Main Rotor Assembly step 2

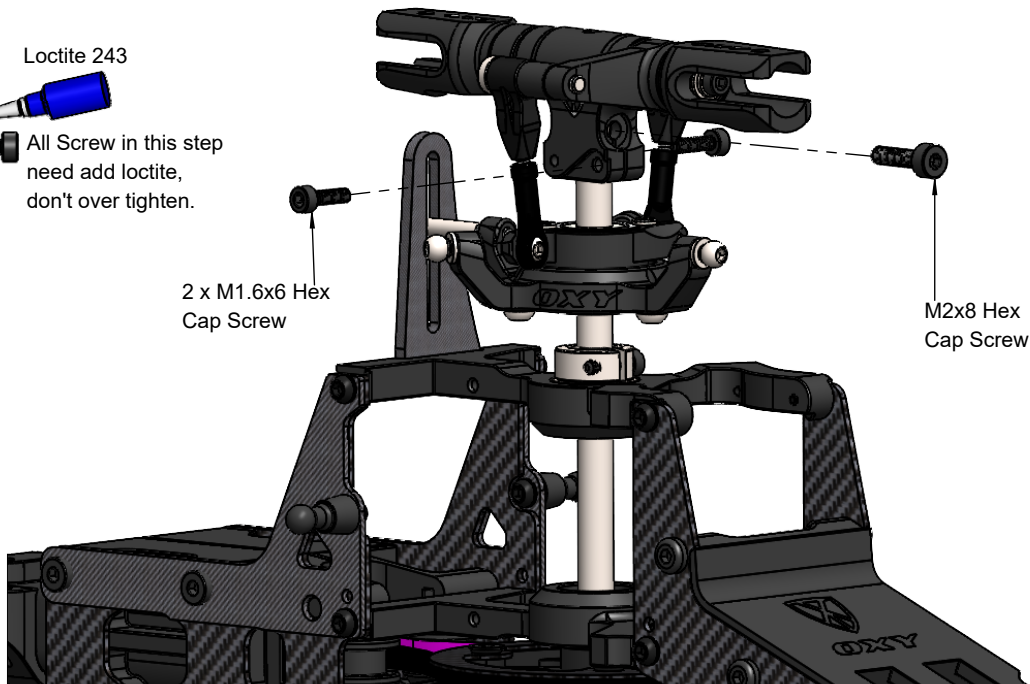

Double - side Tape
(Box 2/Bag 4)

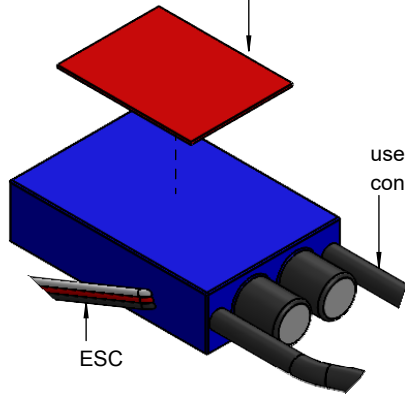

Be carefully Motor wire
and ESC will not touch
Motor/Pinion.

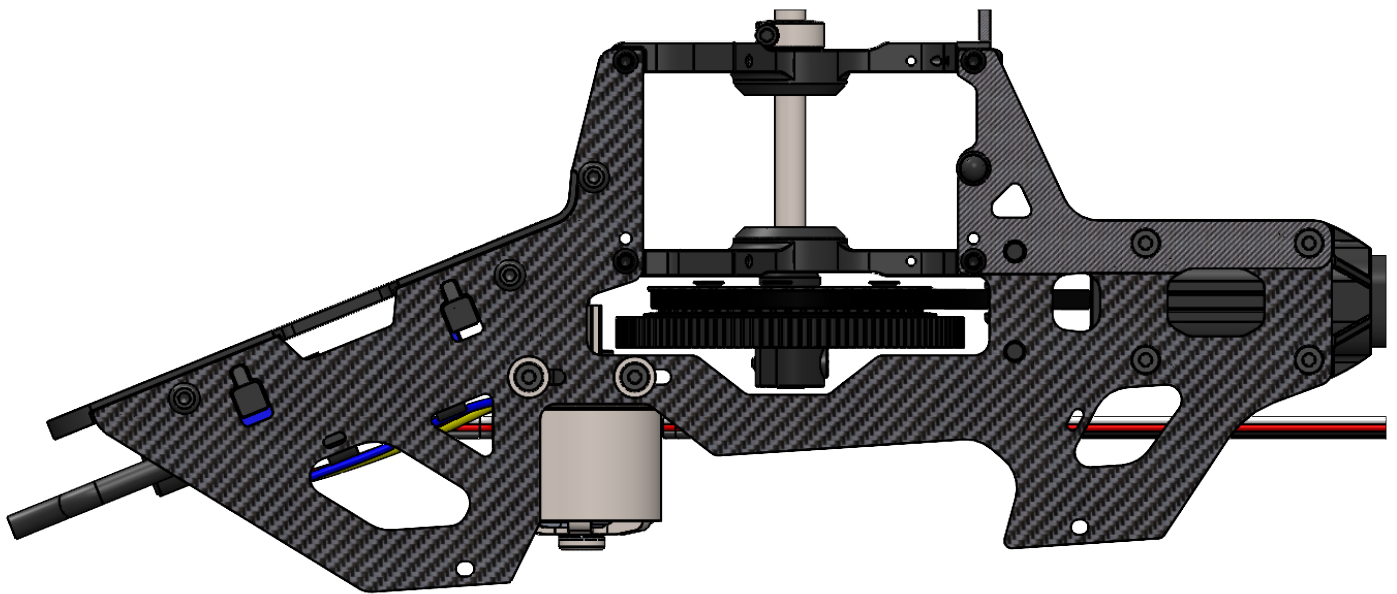
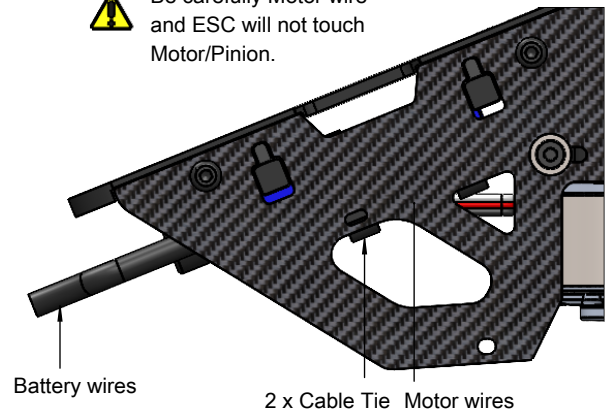

Use 3 x cable ties, to secure the Throttle ESC wire to the main frame. Use the Frame built-in socket for best holding. In this Step connect the Motor and ESC Wires but don't secure yet. Wait till the final motor rotation check, once the FBL system is set up.
NOTE: To reverse Motor rotation direction , just switch 2 of the 3 wires.

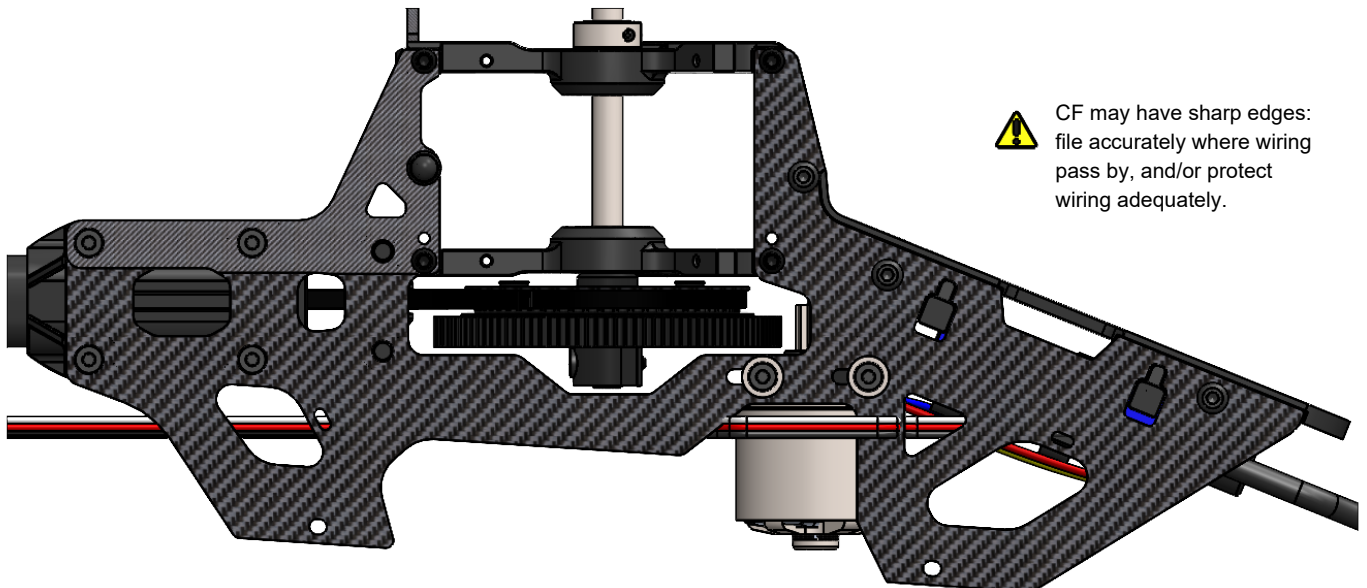

CF may have sharp edges:
file accurately where wiring
pass by, and/or protect
wiring adequately.

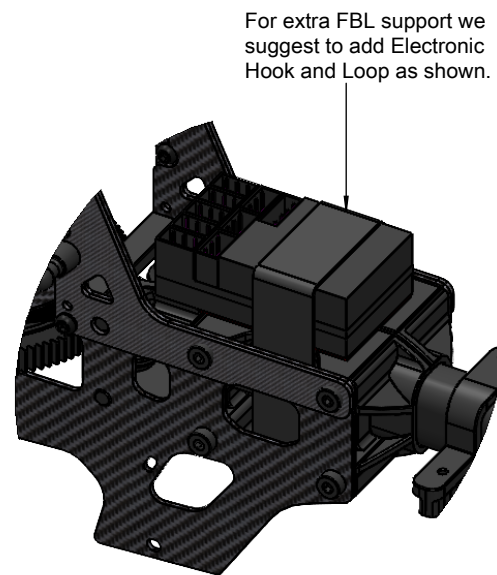
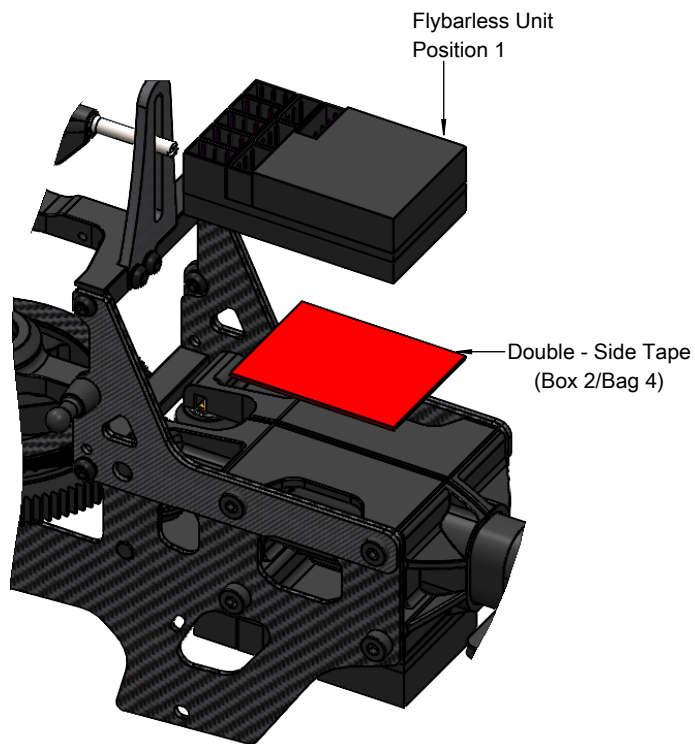

 The FBL system can be installed at the bottom or top of the boom clamp. We suggest to use the bottom for easy wiring and servo removal.

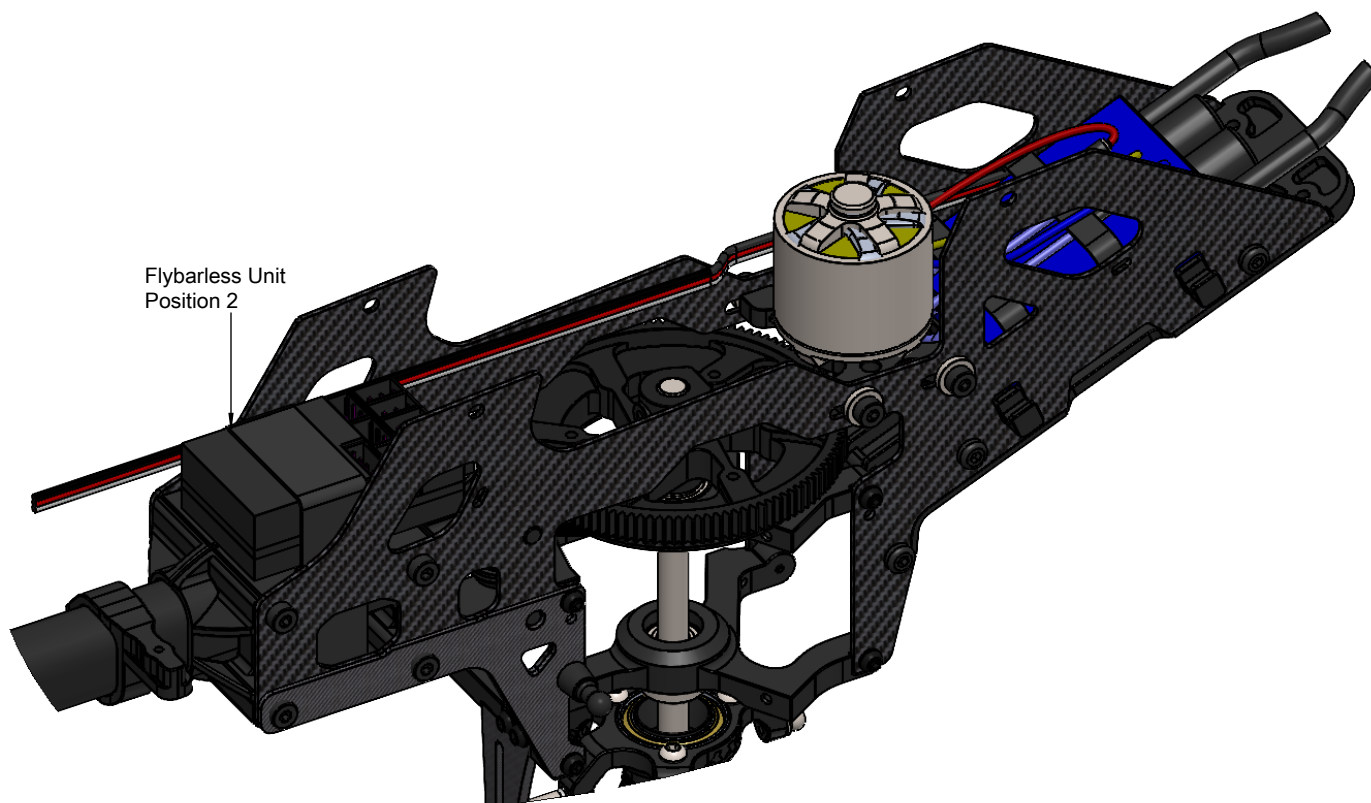

- You should now do some initial setup of your FBL unit and servos.
- We recommend you select a new model in your transmitter, and reset your FBL unit and start with a clean setup in it as well.
- After binding your transmitter to the receiver system used with the FBL unit, work your way through the FBL setup instructions to the point you plug in your servos.
- Now set your collective stick in the middle position, and position the servo arms as close to the correct positions you can on each servo see the following pages for arm orientations on the various servos.
- Next confirm the servos work in the correct direction, then return the collective stick to the center position.
- Now use your FBL unit to trim the servos so the arms are exactly horizontal (see pictures below).
- This procedure varies between units. Carefully label the position of the servos, then proceed with the installation of the servos as shown.

Cyclic Servo.

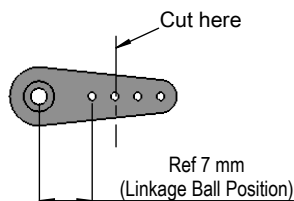

⚠ Linkage Ball Direction: cyclic servo Linkage Ball, must installed as shown.

⚠ Arm position with zero deg pitch and centered cyclic stick.

Reuse STD Servo Arm

Reuse STD Servo Screw

OXY0521-Linkage ball 3x1.5mm (Box 1-1/Bag 7)

CA Glue

Positive Pitch

Negative Pitch

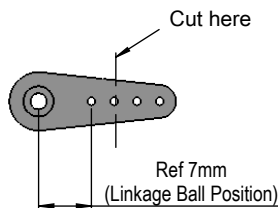

⚠ Linkage Ball Direction: The Tail servo Linkage Ball must be installed as shown.

⚠ Arm position with zero deg pitch and centered rudder stick.

Reuse STD Servo Arm

Reuse STD Servo Screw

OXY0521-Linkage ball 3x1.5mm (Box 1-1/Bag 7)

CA Glue

Nose Right

Nose Left

Servo Rod Assembled
(Box 1-1/Bag 7)

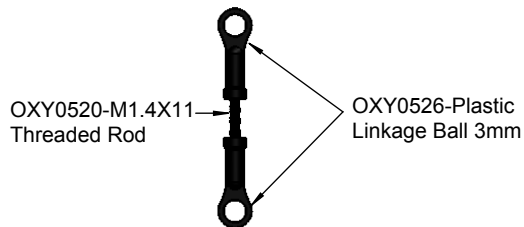
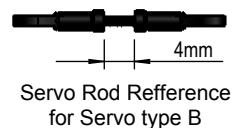
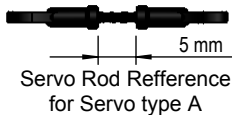

⚠ It is really important the servo rods screw onto the linkages the same amount. The Plastic ball links have a Lynx logo to give you information about turn adjustment, but have a symmetrical ball socket shape and can be installed in either direction to achieve the best fine tuning.

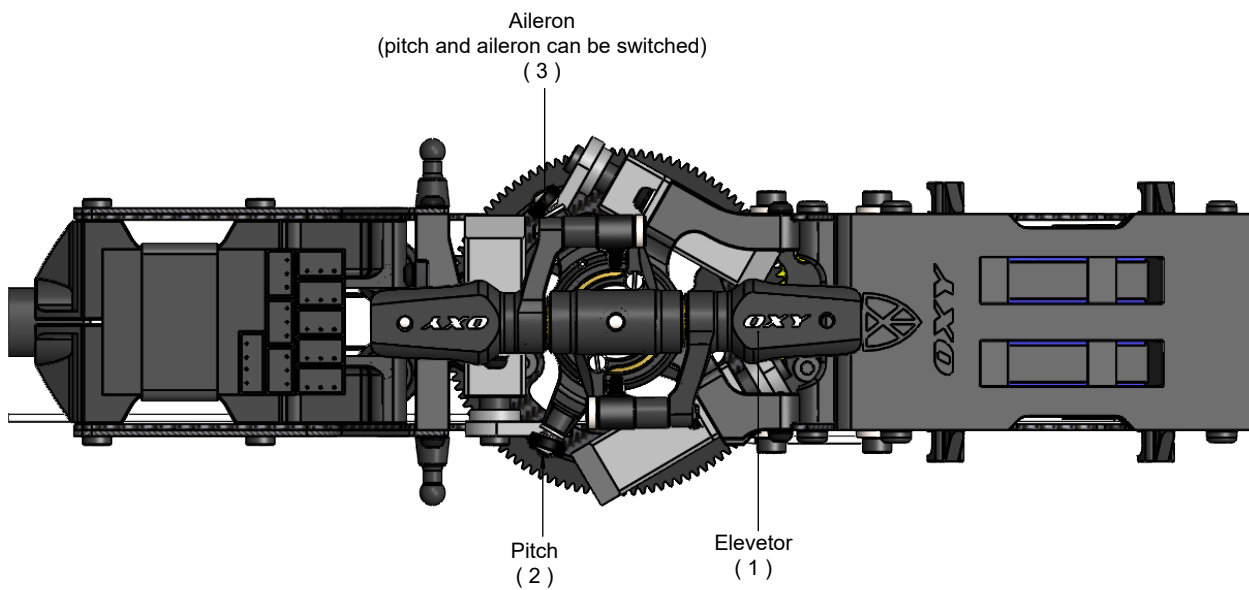
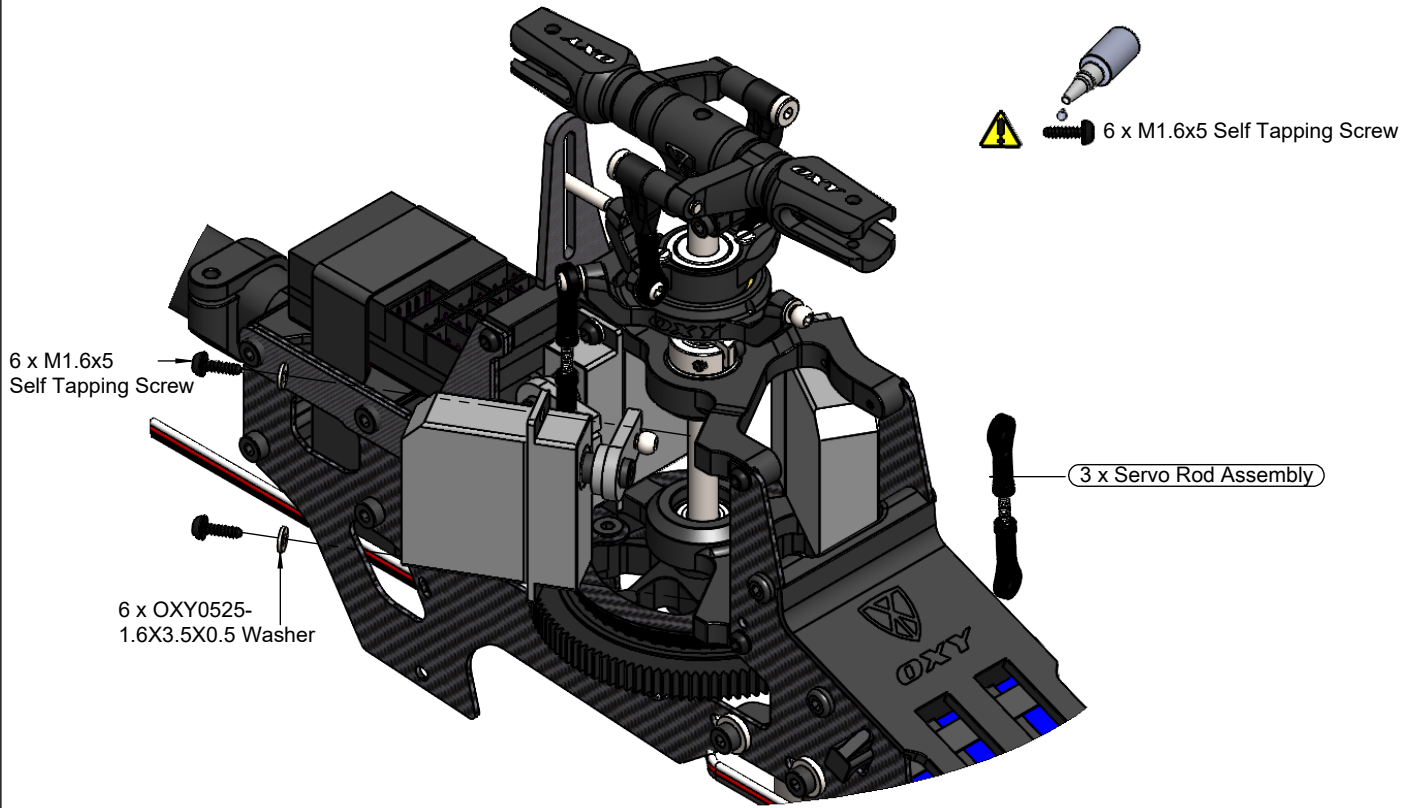

Servo Layout

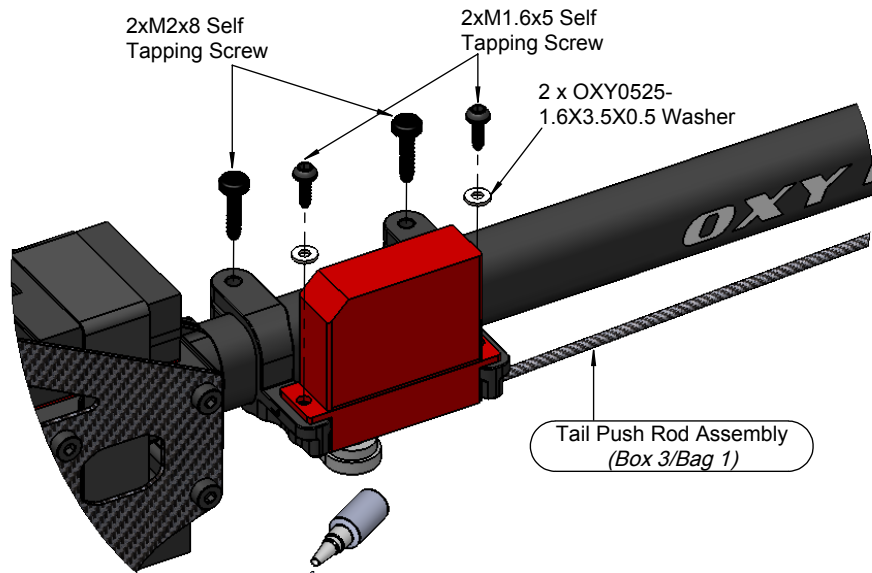

2xM2x8 Self Tapping Screw

2xM1.6x5 Self Tapping Screw

2 x OXY0525-1.6X3.5X0.5 Washer

Tail Push Rod Assembly (Box 3/Bag 1)



M2x8, M1.6x5 Self Tapping Screw

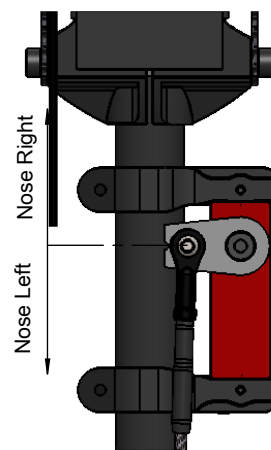

Bottom Heli View



Arm position with centered Rudder stick.



Maximum Tail Servo Size Note:

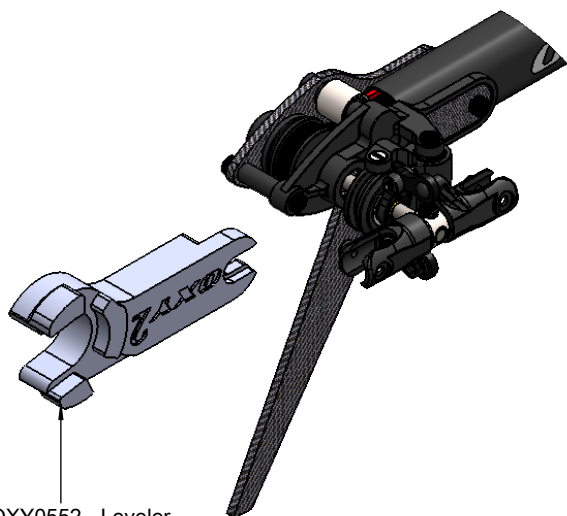
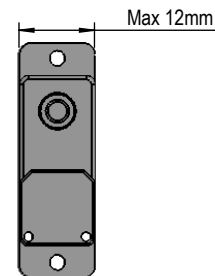

OXY0552 - Leveler (Box 2/Bag 4)

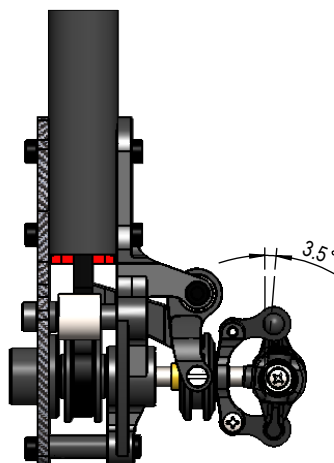

Top Heli View



With Rudder Stick centered and the Tail Servo Arm in the center position, adjust the Tail Push Rod length until the Tail Bell Crank and Tail Case Plate are parallel as shown.



The Oxy 2 Tail System has approximately 3.5 of counter torque with the Tail Bell Crank set per instructions.

Landing Gear & Battery Installation

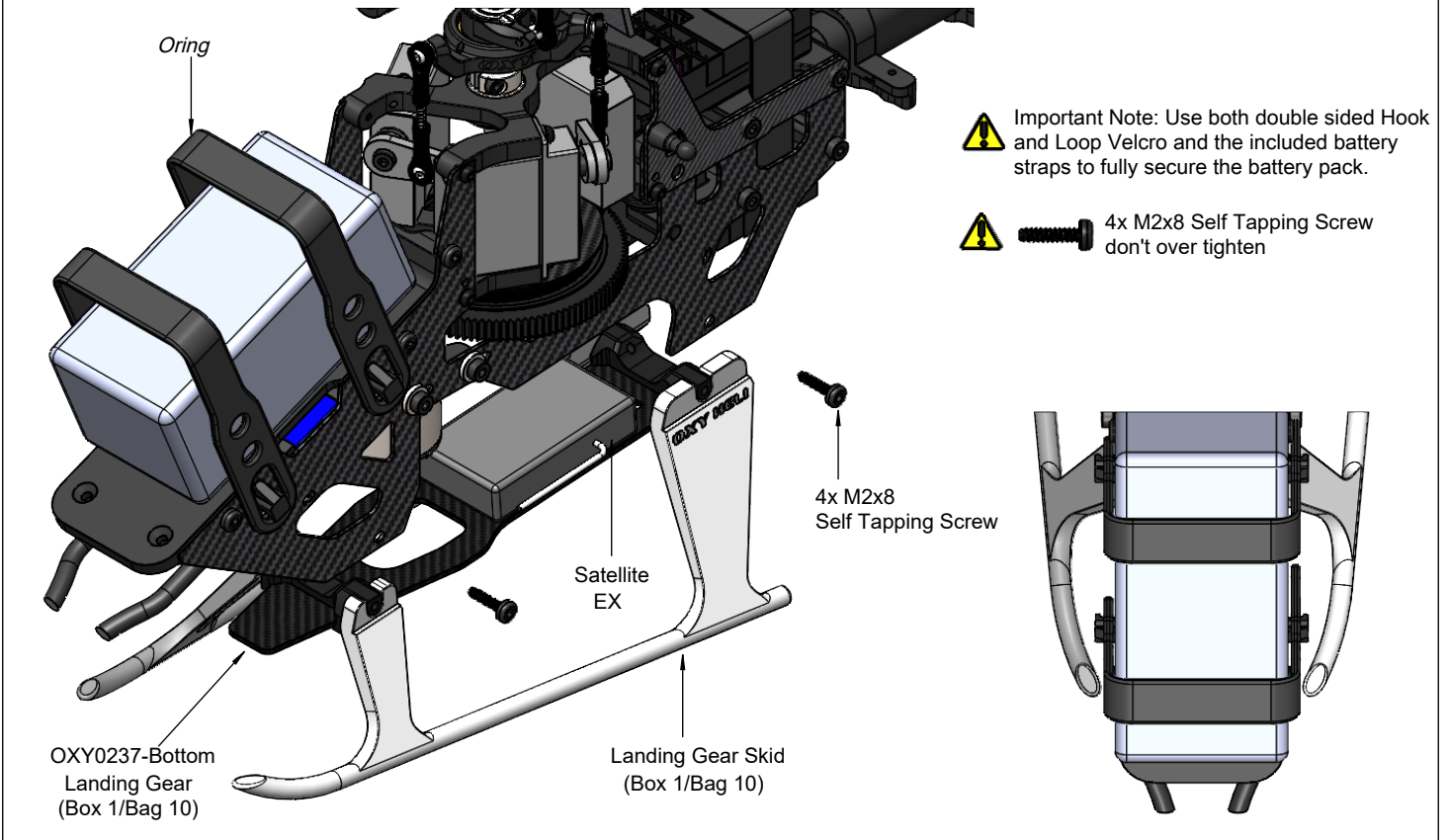

Main Blades Installation

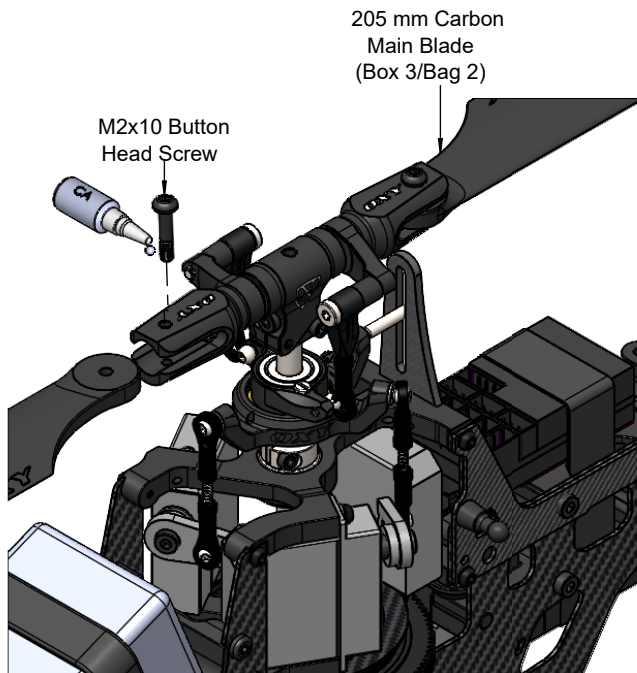

⚠ Note: The Oxy Main Grips have a 3.2mm root cavity in order to work with any standard 190 / 210 main blade root.

Tail Blades Installation

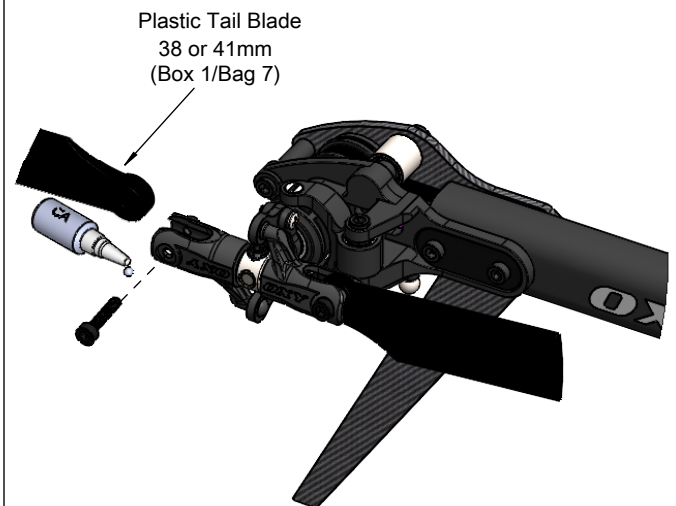

⚠ Oxy tail blade dimension note: In order to assure the best performance Oxy made a custom tail blade with a 3mm root. If you use different tail blades with a 2.5mm root you must use shims (not included).

Information about 38 and 41mm tail blades: In the kit we include two sets of tail blades - the 38mm are designed for high head speed, the 41mm are designed for low head speed. We recommends using 38mm when head speed is higher than 4000rpm.

OXY HELI

Before Fly:

Now complete the setup of your FBL system. In the Accessories Bag you will find an Oxy 3 Swash Plate Leveler.

This Tool is designed to fit under the Swash Plate without disassembly any parts. This simple tool will both level the swash and give the Zero Pitch Position.

Starting gyro gain: The Oxy 2 was designed around famous FBL Systems (IKON / Brain / mini V-Bar), and we suggest you start with the following standard set up and adjust after test flying.

Cyclic Set Up:

Use suggested settings for 450 Helicopters and adjust after test flights.

See our table on page 15 for RPM and Pitch Settings. Cyclic Max pitch should be +/- 10.5 deg.

Tail Set Up:

Use the suggested settings for 450 Helicopters BUT start with a lower Tail Gain

IKON / Brain = 20%

Mini V-Bar = 250 Heli suggested gain.



Lift up swash plate as shown to have space for inserting Leveler.

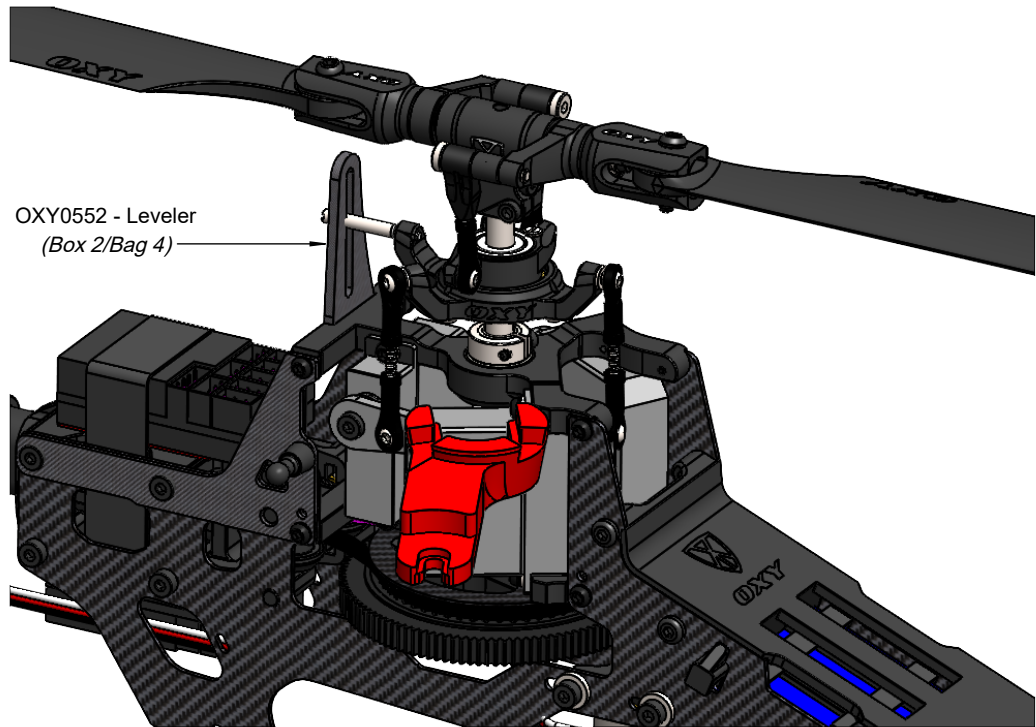

Lift Swash Plate down until Swash Plate touch Leveler as shown.

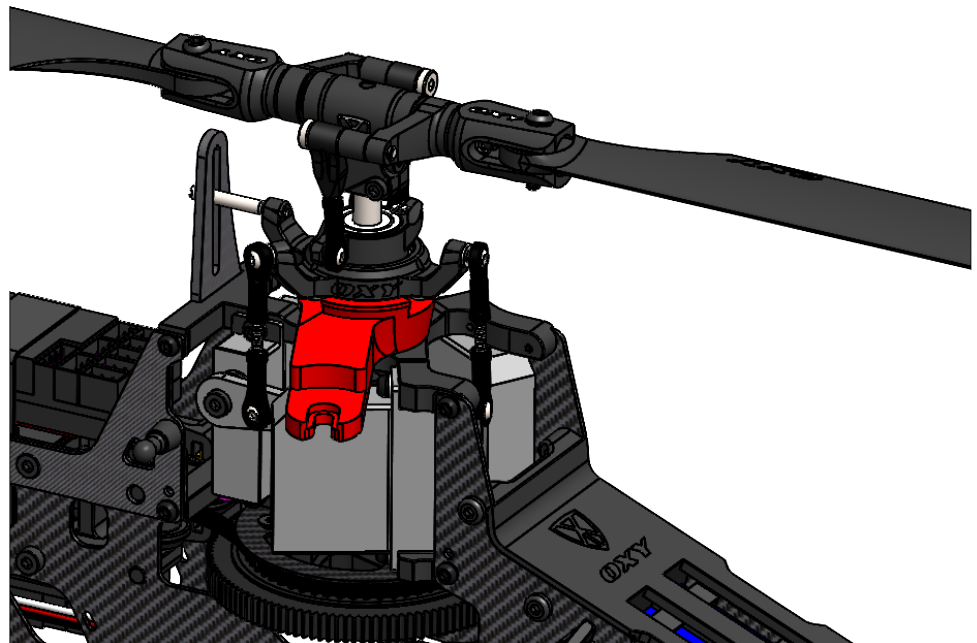

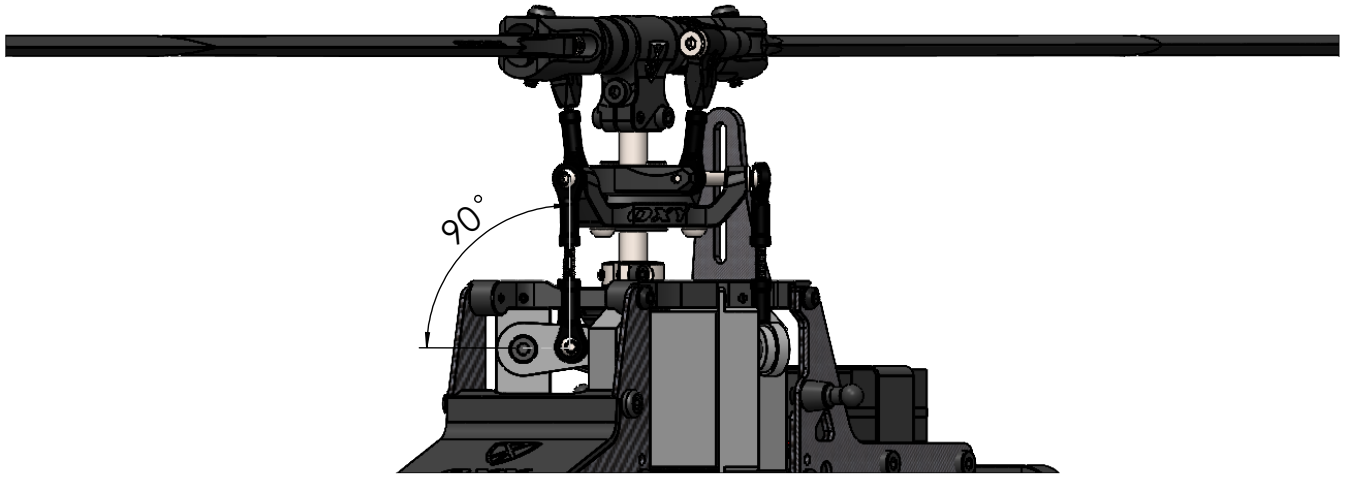

Front Servo

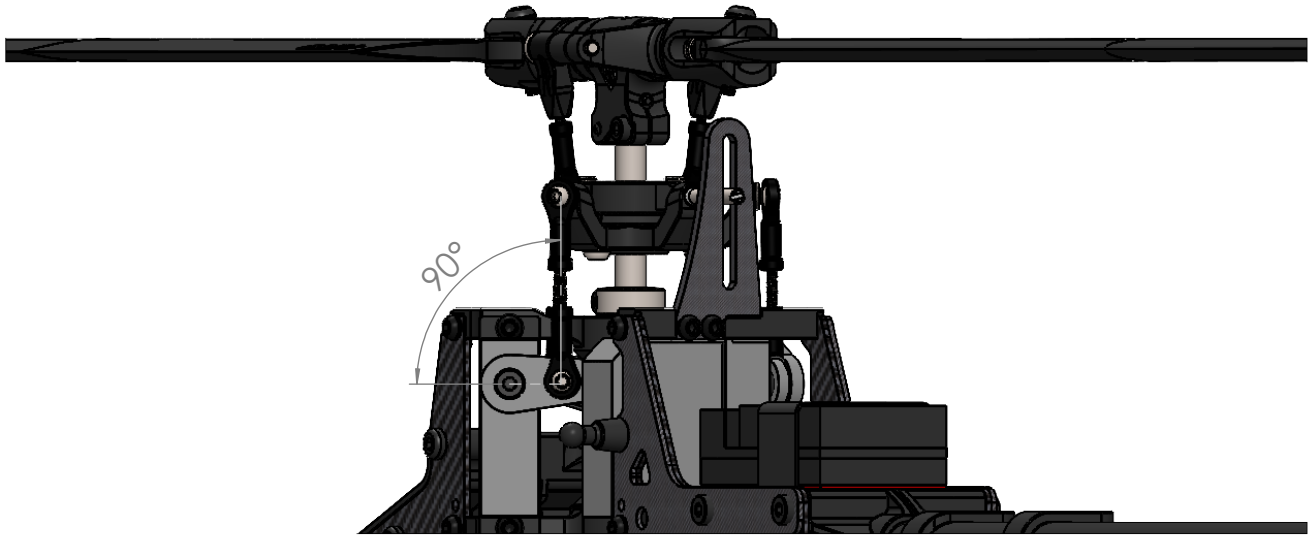

Left Servo

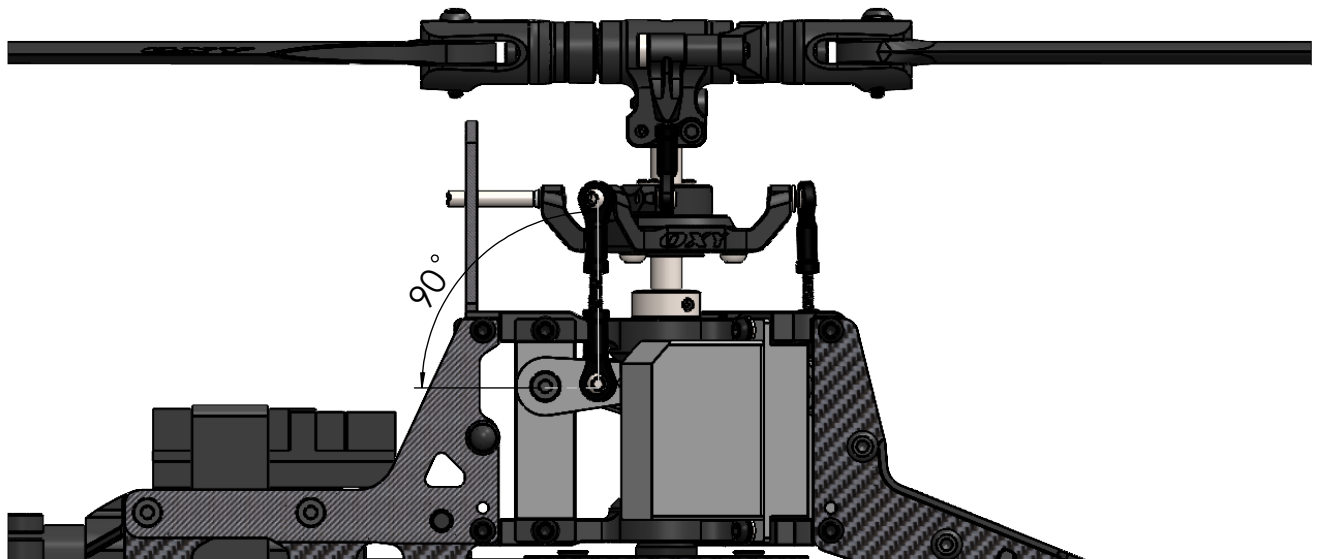

Right Servo

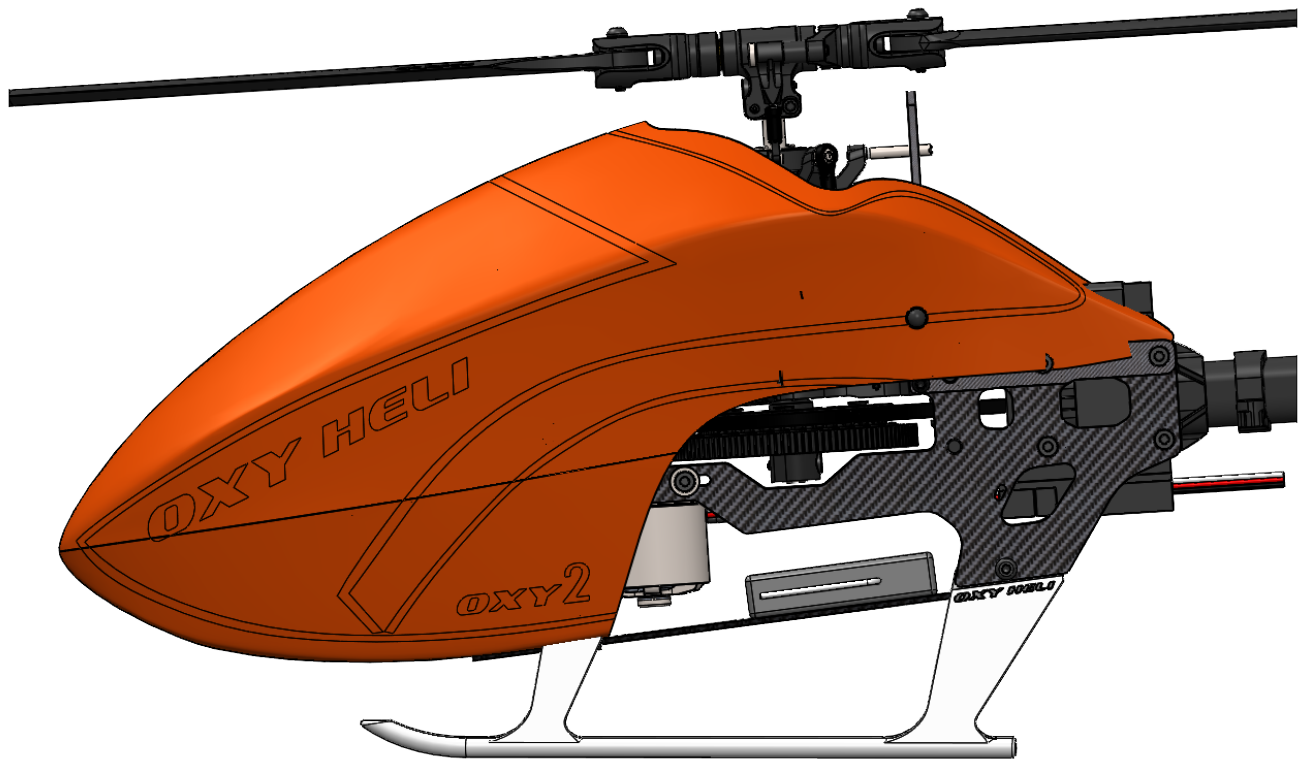

Oxy 2 Sport Lexan Canopy Temperature Range Warning:

Because Lexan Canopy is produced by thermoforming, the material used cannot be exposed temperature over 60 deg C (140 deg F).

We recommend, on very hot days, avoid to leave the canopy inside a closed car under direct sun for long time.

We recommend to don't use any hot air gun direct on the canopy.

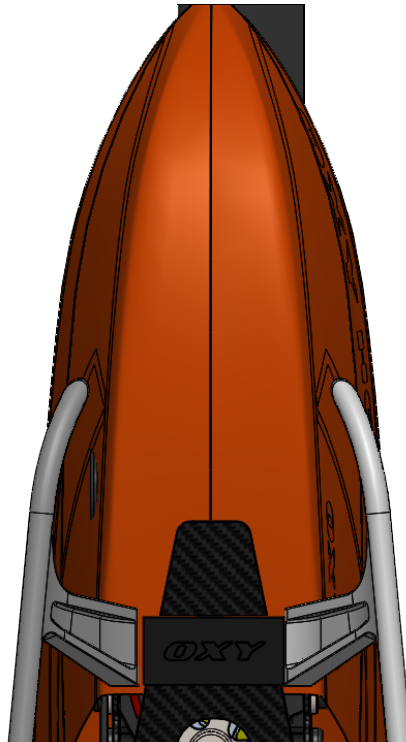

OXY HELI

Note: This tool not included in PL 190mm Kit

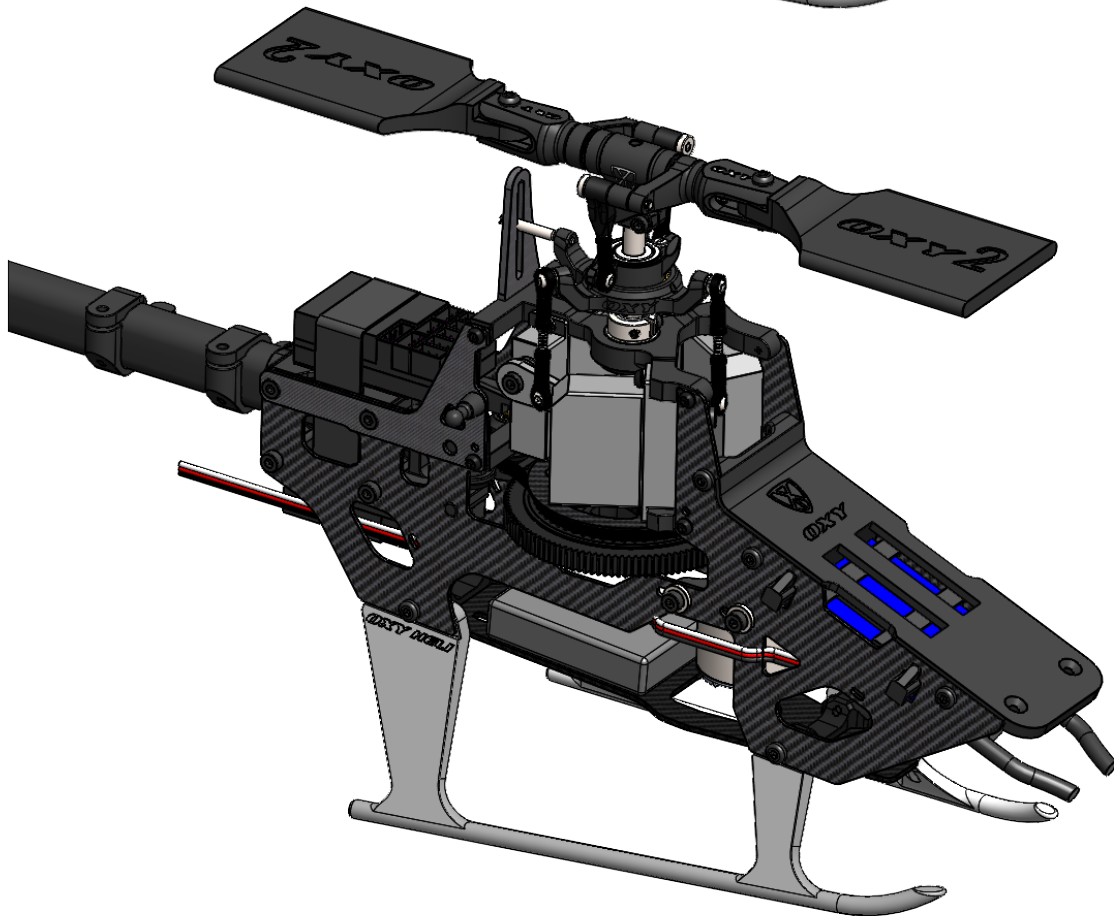
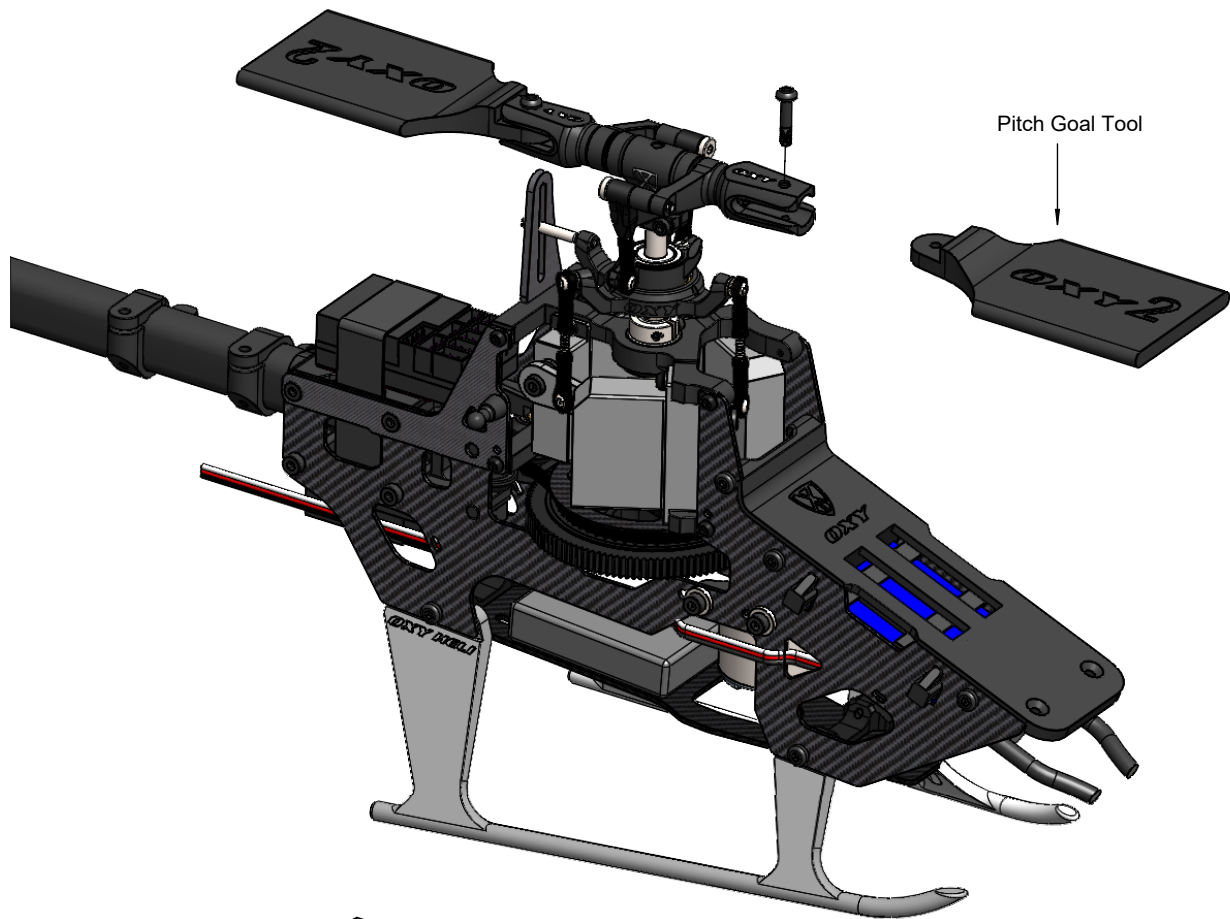

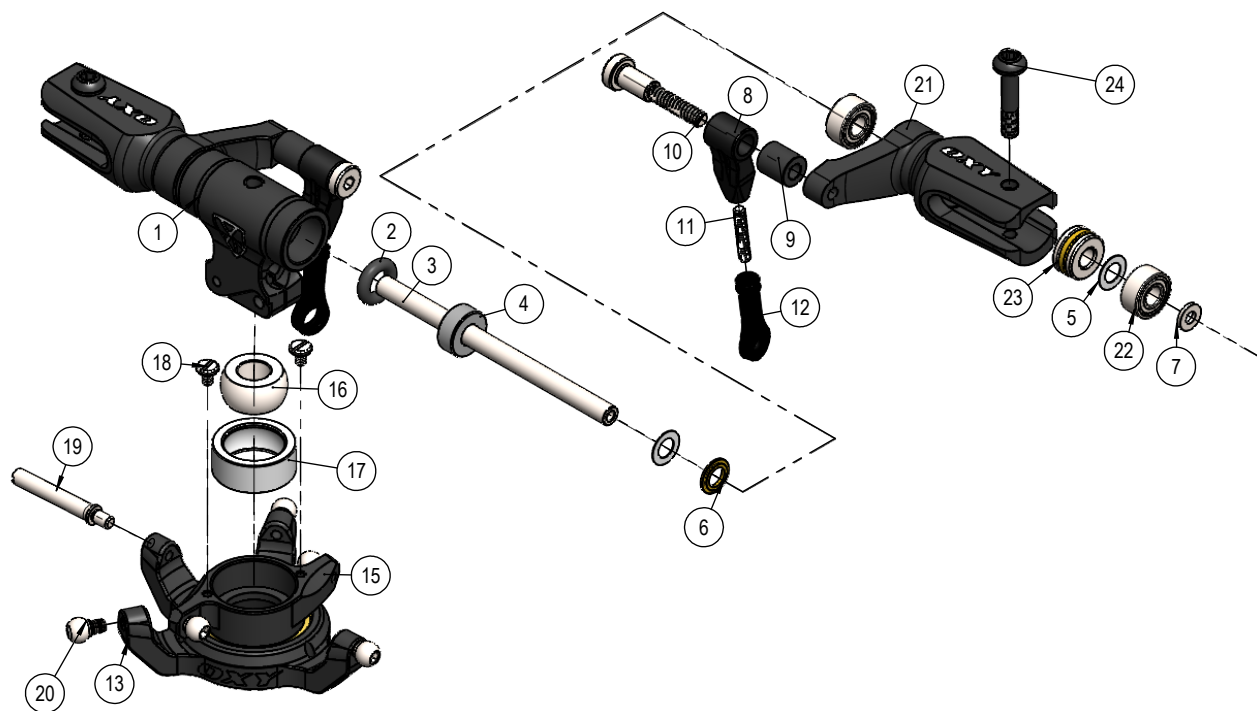

POS	Code	Name	QTY.
1	OXY0227	OXY2-CENTER HUB	1
2	OR3W1.5	Oring ID3x1.5	2
3	OXY0446	OXY2 Sindle Shaft	1
4	OXY0229	OXY2-Dampener Bushing	2
5	OXY0524	2.55x4.5x0.1 Shim	4
6	OXY0528	OXY2-Damperner Spacer	2
7	OXY0525	1.6x3.5x0.5 Washer	2
8	OXY0529	OXY2-DFC Arm	2
9	OXY0530	OXY2-2x4X4.4 Bushing	2
10	OXY0447	OXY2-DFC Pin Screw	2
11	OXY0519	Threaded Rod M1.4X7mm	2
12	OXY0526	Plastic Linkage Ball 3mm	2
13	OXY0234	OXY2-Lower Swash Plate	1
14	MR6700 ZZC	10X15W4 Radial Bearing	1
15	OXY0233	OXY2-Upper Swash Plate	1
16	OXY0017	Center Ball	1
17	OXY0016	Ball Holder	1
18	OXY0020	M1.2x2 SPECIAL SCREW	2
19	OXY0454	OXY2-Anti Rotation PIN	1
20	OXY0521	Linkage ball 3x1.5mm - DR1265	5
21	OXY0228	OXY2- Main Grip	2
22	SMR682Z-ZZ	2.5X6X2.6 Radial Bearing	4
23	F2.5-6GC	2.5x6x3 Thrust Bearing	2
24	OXY0078	M2X10 Botton Screw	2
25	OXY0598	OXY2-PL Lower Swash Plate	1

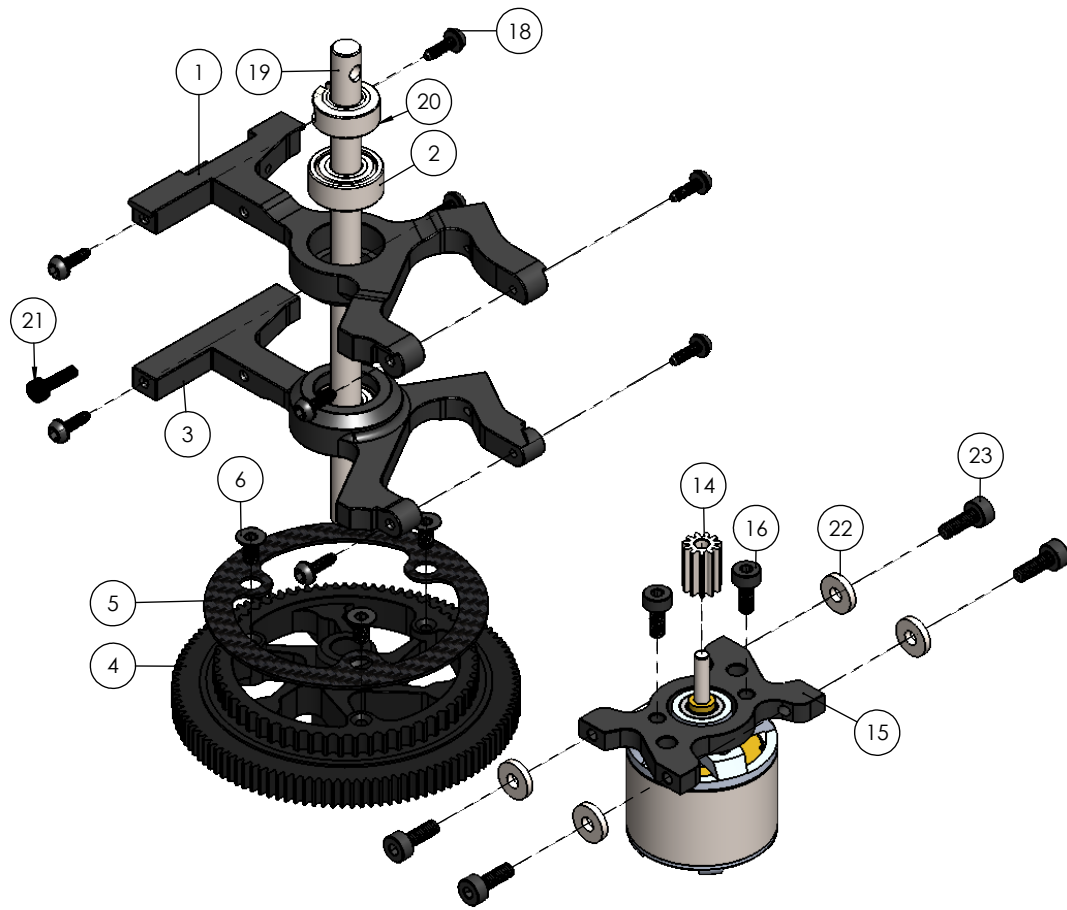

POS	PartNo	DESCRIPTION	QTY.
1	OXY0602	Upper Main Shaft Bearing Block	1
2	MR104_ZZC	4X10X4 RADIAL BEARING	2
3	OXY0603	Lower Main Shaft Bearing Block	1
4	OXY0690	113T-55T Pulley Strait Main Gear	1
5	OXY0538	CF Main Gear Cover	1
6	FHSM2X4	M2x4 Flat Head Screw	3
14	OXY0744	OXY2-11T 0.4M 2mm Shaft Straight Pinion	1
15	OXY0238	OXY2-MOTOR MOUNT	1
16	TCEM2X5	M2X5 HEX CAP SCREW	2
17	OXY0263	OXY2-Main Frame	1
18	TBESM1.6x5	M1.6x5 Self Tapping Screw	8
19	OXY0459	OXY2-Main Shaft	1
20	OXY0451	OXY2-Main Shaft Collar	1
21	TCEM1.6X6	M1.6x6 Hex Cap Screw	1
22	OXY0081	2.1X5.5X1 WASHER	4
23	TCEM2X6	M2X6 Hex Cap Screw	4

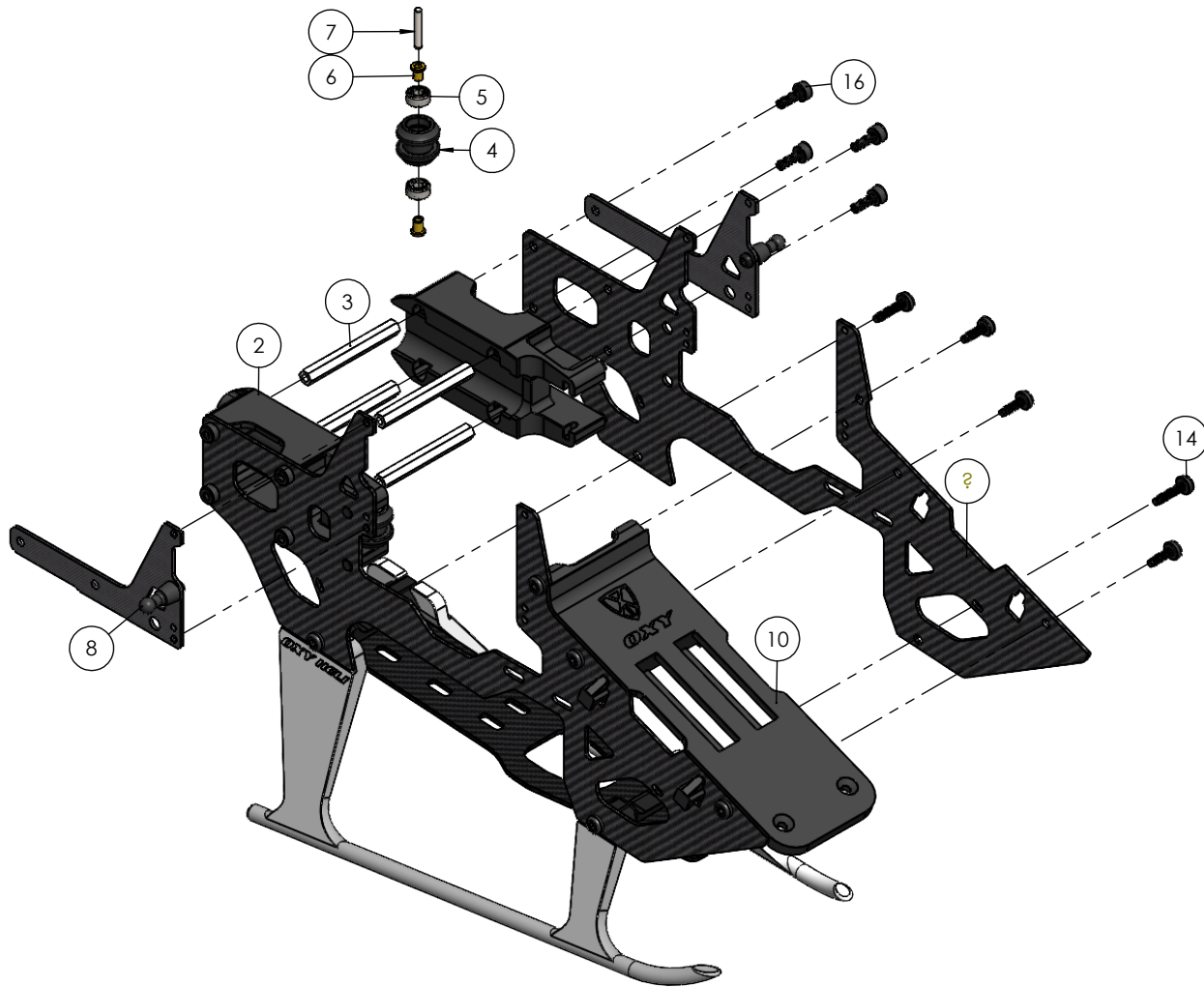

POS	PartNo	DESCRIPTION	QTY.
1	OXY0263	OXY2-Main Frame	2
2	OXY0452	OXY2-Boom Clamp	2
3	OXY0453	Boom Lock Rod	4
4	OXY0623	OXY2-Pulley Guide Belt	2
5	MR52-W2	2X5X2 Radial Bearing	4
6	OXY0460	OXY2 Bell Crank Bushing	4
7	OXY0089	1.5x9.5 Alloy Steel Dowel Pin	2
8	OXY0601	Canopy Mount	2
9	TBESM1.6x5	M1.6x5 Self Tapping Screw	2
10	OXY0300	OXY2- Battery Tray	1
11	OXY0237	OXY2-Bottom Landing Gear	1
12	OXY0240	OXY2-Right Landing Gear	1
13	OXY241	OXY2-Left Landing Gear	1
14	TBES2X8	M2X8 Self Tapping Screw	4
15	TBES2X6	M2X6 Self Tapping Screw	6
16	TCEM2X6	M2X6 Hex Cap Screw	8
17	OXY1290	OXY2 Stiffener fbl funtion	2

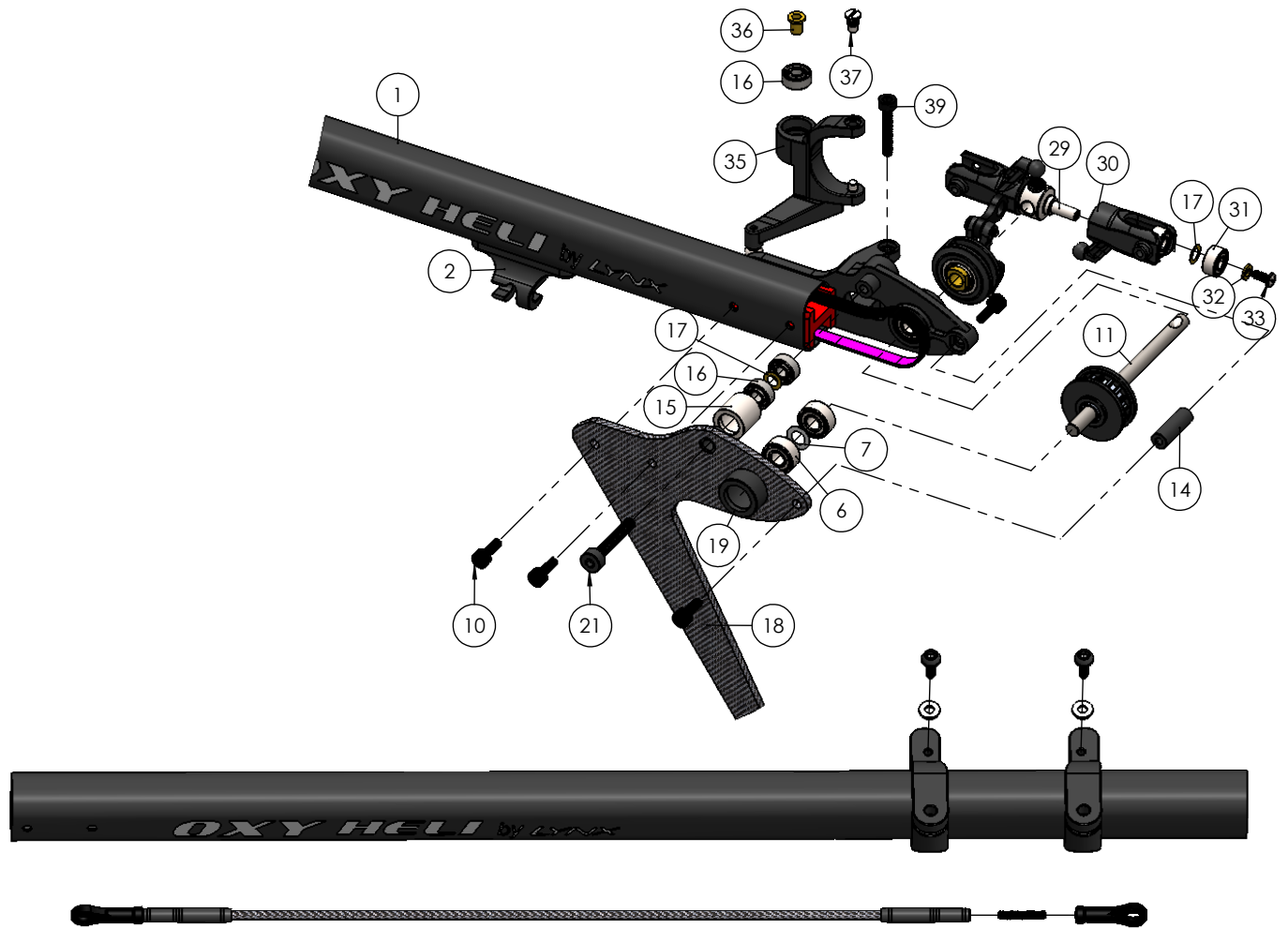

POS	PartNo	DESCRIPTION	QTY.	POS	PartNo	DESCRIPTION	QTY.
1	OXY0578	OXY 2 Tail Boom STD (Black)	1	22	OXY0607	OXY 2-Tail Ptch Slider Ring	1
2	OXY0622	OXY 2-TE Guide Push Rod	1	23	MR683	3x7x2 Radial Bearing	2
3	OXY0539	M2.5 Pin Screw	2	24	OXY0457	OXY 2-Tail Ptch Slider Bushing	1
4	OXY0258	OXY 2-Tail Case Center	1	25	OXY0608	Tail Pitch Slider Halfmoon	1
5	OXY0513	OXY 2-Plastic Side Case	1	26	OXY0522	OXY 2-Link Control	2
6	SMR682Z-ZZ	2.5X6X2.6 Radial Bearing	4	27	OXY0523	OXY 2-Link Control Buhing	2
7	OXY0524	2.55x4.5x0.1 Shim	3	28	PanM1.4x5	M1.4x5 Pan Head Screw	2
8	OXY0514	OXY 2-Tail Case Stiffener	1	29	OXY0253	OXY 2-Tail Hub	1
9	B305MXL	305T W2.5 Timing Belt	1	30	OXY0624	OXY 2-PL Tail grip	2
10	TCEM1.6X5	M1.6X5 Hex Cap Screw	6	31	SMR682-ZZ	2X5X2.3 Radial Bearing	4
11	OXY0256	OXY 2-TAIL SHAFT	1	32	OXY0551	1.5x2.8H0.4 Washer	2
12	OXY0458	OXY 2-16T MXL TAIL PULLEY	1	33	PanM1.4x3	M1.4x3 Pan Head Screw	2
13	OXY0456	OXY 2-Tail Flange Pulley	2	34	SCM3x3	Flat-Tip Set Screw M3x3	1
14	OXY0540	OXY 2-Tail Case Rod	1	35	OXY0604	OXY 2-Tail Bell Crank	1
15	OXY0515	OXY 2-Tensioner Bushing	1	36	OXY0460	OXY 2 Bell Crank Bushing	2
16	MR52-W2	2X5X2 RADIAL BEARING	4	37	OXY0448	OXY 2-Bell Crank Pin Screw	2
17	OXY0527	2x3.5x0.1 Shim	3	38	OXY0628	3mm Steel Ball 3mm thread long	1
18	OXY0745	OXY 2 Vertical Fin PL Tail Case Version	1	39	TCEM1.6X10	M1.6X10 Hex Cap Screw	1
19	OXY0279	OXY 2-Vertical Fin Bushing	1	40	OXY0605	OXY 2-Tail Servo Support	1
20	OXY0516	2x3.5x2.2 Bushing	1	41	OXY0606	OXY 2-Tail Servo Support	1
21	TCEM2X12	M2X12 Hex Cap Screw	1	42	OXY0450	OXY 2-Front Boom Insert	1

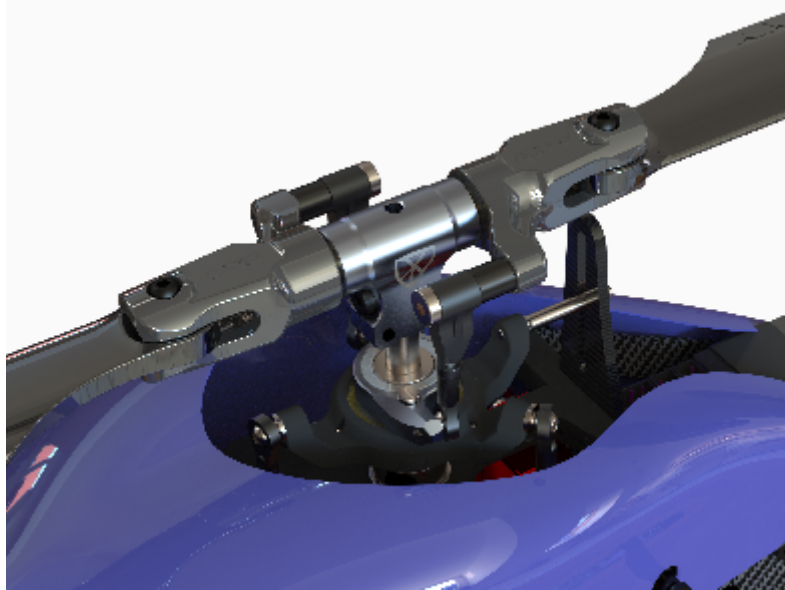

**SP-OXY2-001-OXY2-
CNC Aluminum Center Hub, Black**



- 1 x OXY2-Center Hub
- 2 x M1.6x6 Hex Cap Screw
- 1 x M2X8 Hec Cap Screw

**OSP-1249
Aluminum Main Grip, Black**



- 2 x OXY2- Main Grip
- 4 x 2.5X6X2.6 Radial Bearing
- 2 x 2.5x6x3 Thrust Bearing
- 2 x 2.55x4.5x0.1 Shim
- 2 x M2X10 Bottom Screw

**SP-OXY2-003 - OXY2 -
Damperner, Set**



- 2 x OXY2-Damperner Spacer
- 2 x 2.55x4.5x0.1 Shim
- 2 x OXY2-Dampener Bushing
- 2 x O'ring ID3x1.5

**SP-OXY2-004 - OXY2 -
Plastic DFC Arm, Set**



- 2 x OXY2-DFC Arm
- 2 x Threaded Rod M1.4X7mm
- 2 x Plastic Linkage Ball 3mm

**SP-OXY2-005 -
3 mm Linkage Ball, 10Pcs**



- 10 x Plastic Linkage Ball 3mm

**SP-OXY2-006 -
M1.4x11 Threaded Rod, 10Pcs**



- 10 x M1.4X11 Threaded Rod

**SP-OXY2-007 -
OXY2 - Main Shaft, 2 PCS**



- 2 x OXY2-Main Shaft
- 1 x OXY2-Main Shaft Collar
- 1 x M1.6x6 Hex Cap Screw
- 4 x M2X8 Hex Cap Screw

**SP-OXY2-008 - OXY2 -
Spindle Shaft, 2 Set**



- 2 x OXY2 Sindle Shaft
- 4 x 1.6x3.5x0.5 Washer
- 4 x M1.6X5 Hex Cap Screw

**SP-OXY2-009 -
3mm Steel Ball, 10 PCS**



- 10 x Linkage ball 3x1.5mm

SP-OXY2-010 - OXY2 - Swash Plate, Service Bag



- 1 x Ball Holder
- 1 x Center Ball
- 2 x M1.2x2 Special Screw

SP-OXY2-113 OXY2 - PL Swash Plate, Set



- 1 x OXY2-Lower Swash Plate
- 1 x OXY2-Upper Swash Plate
- 1 x 10X15W4 Radial Bearing
- 1 x Center Ball
- 1 x Ball Holder
- 2 x M1.2x2 Special Screw
- 1 x OXY2-Anti Rotation Pin
- 1 x Linkage ball 3x1.5mm

SP-OXY2-013 - OXY2 - Main Grip Service Bag



- 4 x 2.5X6X2.6 Radial Bearing
- 2 x 2.5x6x3 Thrust Bearing
- 2 x 2.55x4.5x0.1 Shim
- 2 x M2X10 Button Screw

SP-OXY2-058 - OXY2 - DFC Pin Screw, Set



- 2 x OXY2-DFC Pin Screw
- 2 x OXY2-2x4X4.4 Bushing

SP-OXY2-099 Linkage Ball ø 3x6mm, 10Pc



- 10 x ø 3x6mm

SP-OXY2-125 OXY2 - PL Main Grip Spare, 4Pcs



- 4 x PL Main Grip

SP-OXY2-129 OXY2 - DFC Spare, 4Pcs



- 4 x DFC

SP-OXY2-130 Threaded Rod M1.4x7 , 10Pcs



- 10 x M1.4x7 Threaded Rod

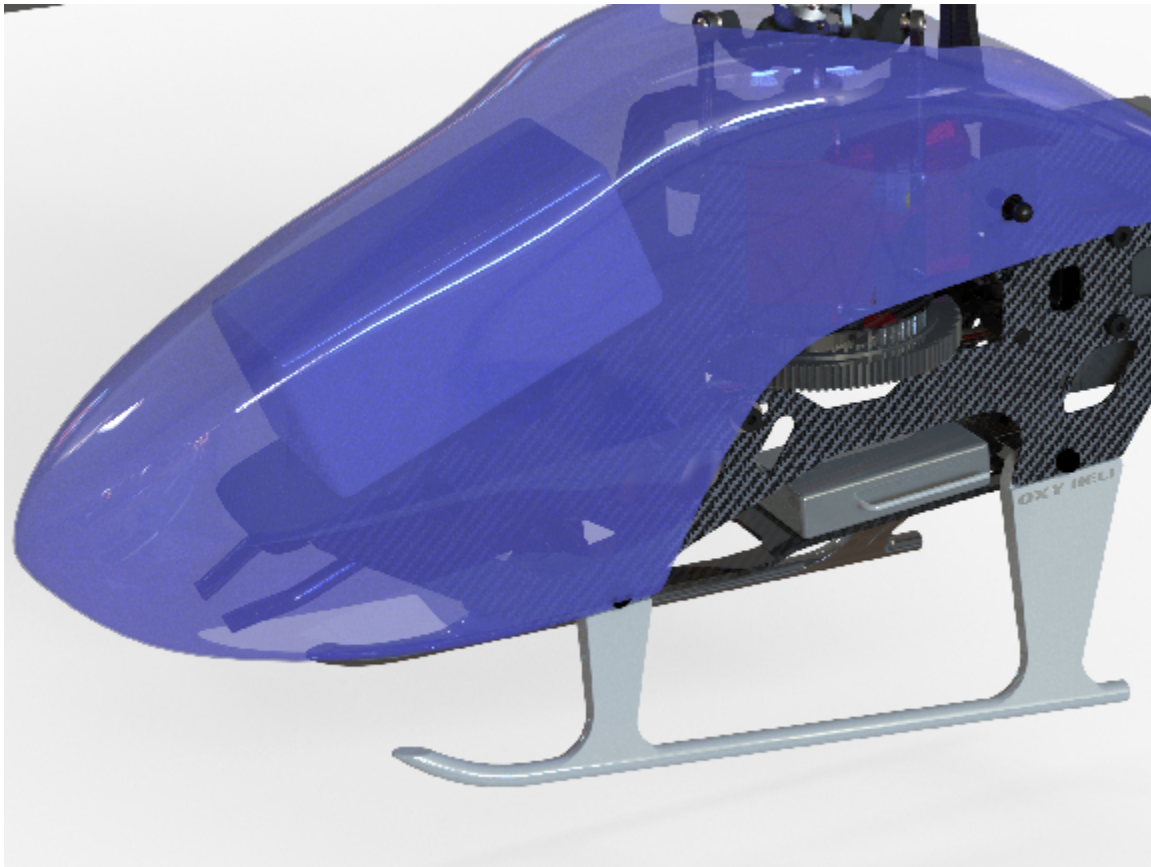

**SP-OXY2-014 - OXY2 -
Anti Rotation Guide**



1 x OXY2-Anti Rotation Guide

**SP-OXY2-114
OXY2 - PL Main Shaft Bearing Block, Set**



1 x Upper Main Shaft Bearing Block
9 x M1.6X5 Hex Cap Screw
3 x 1.6x3.5x0.5 Washer
1 x 4X10X4 Radial Bearing

**SP-OXY2-115
OXY2 - PL Main Shaft Bearing Block Only, Set**



1 x Lower Main Shaft Bearing Block
7 x M1.6X5 Hex Cap Screw
3 x 1.6x3.5x0.5 Washer
1 x 4X10X4 Radial Bearing

**SP-OXY2-017 - OXY2 -
Motor Mount, Set**



1 x OXY2 - Motor Mount
6 x M2X6 Hex Cap Screw
4 x 2.1X5.5X1 Washer
2 x M2.5x5 Button Screw

**SP-OXY2-116
OXY2 - 113T Straight Main Gear**



1 x CNC Main Gear 55t Pulley
1 x CF Main Gear Cover
3 x M2x4 Flat Head Screw
1 x M2X8 Hex Cap Screw

**OSP-1486-
OXY2-Main Frame, Pro Edition**



2 x OXY2-Main Frame

**OSP-1487-
OXY2 - CF Break Away Canopy , pro Edition**



2 x OXY2-Break Away Canopy

**SP-OXY2-021 - OXY2 -
CNC Aluminum Canopy Mount**



2 x Canopy Mount
2 x M1.6X4 Hex Cap Screw

**SP-OXY2-022 - OXY2 -
Bottom Plate**

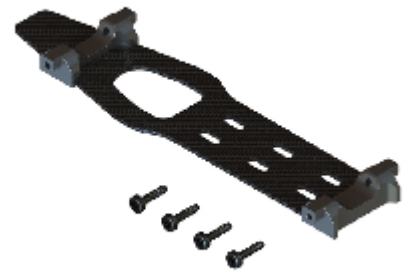

1 x OXY2-Bottom Landing Gear
4 x M2X8 Self Tapping Screw

**SP-OXY2-023 - OXY2 -
Plastic Landing Gear Skid, Left / Right**



1 x OXY2-Right Landing Gear, black
1 x OXY2-Left Landing Gear, black

**SP-OXY2-069
OXY2 - Battery Tray , Set**

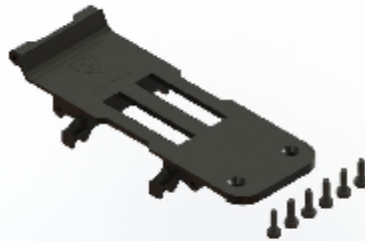

1 x OXY2- Battery Tray
6 x M2X6 Self Tapping Screw

**SP-OXY2-070
OXY2 - Tail Boom Clamp Mount, set**

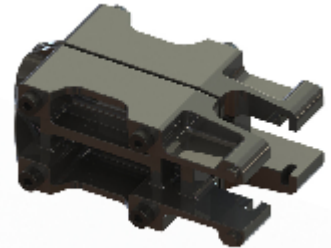

2 x OXY2-Boom Clamp
4 x Boom Lock Rod
8 x M2X6 Hex Cap Screw

**SP-OXY2-123
OXY2 - PL Belt Pulley Guide, Set**



4 x OXY2-Pulley Guide Belt
4 x 2X5X2 Radial Bearing
4 x OXY2 Bell Crank Bushing
2 x 1.6x13.8mm Pin

**SP-OXY2-027 - OXY2 -
Boom Mount Lock Rod, Set**



4 x Boom Lock Rod
8 x M2X6 Hex Cap Screw

**SP-OXY2-057 - OXY2 -
Main Gear Spacer**

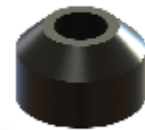

1 x OXY2-Main Gear Bushing

**SP-OXY2-124
OXY2 - Main Gear Cover, 3Pcs**



3 x Main Gear Cover
3 x Flat Srew M2x4



**SP-OXY2-029 - OXY2 -
Tail Shaft 15T**



1 x OXY2-Tail Shaft
1 x 15T Tail Pulley
2 x OXY2-Tail Flange Pulley
4 x 2.55x4.5x0.1 Shim

**SP-OXY2-030 - OXY2 -
Tail Shaft 16T**



1 x OXY2-Tail Shaft
1 x 16T Tail Pulley
2 x OXY2-Tail Flange Pulley
4 x 2.55x4.5x0.1 Shim

**SP-OXY2-031 - OXY2 -
Tail Rotor Hub, Spare**



1 x OXY2-Tail Hub
2 x M1.4x3 Pan Head Screw
2 x 1.5x2.8H0.4 Washer
1 x Set Screw M3x3

**SP-OXY2-117
OXY2 - PL Tail Grip, Set**



2 x OXY2-PL Tail Grip
4 x 2X5X2.3 Radial Bearing
2 x 2x3.5x0.1 Shim
2 x M1.6x8 Hex Cap Screw

**SP-OXY2-033 - OXY2 -
Tail Rotor - Service Bag**



4 x 2X5X2.3 Radial Bearing
2 x 2x3.5x0.1 Shim
2 x Linkage ball 3x1.5mm
2 x M1.6x8 Hex Cap Screw

**SP-OXY2-118
OXY2 - PL Tail Bell Crank**



1 x OXY2-PL Tail Bell Crank
2 x 2X5X2 Radial Bearing
2 x OXY2-Bell Crank Pin Screw
1 x Linkage ball 3x1.5mm
2 x OXY2 Bell Crank Bushing
1 x M1.6X10 Hex Cap Screw

SP-OXY2-119
OXY2 - PL Tail Case



- 1 x PL Tail Case
- 2 x 2.5X6X2.6 Radial Bearing
- 1 x 2.55x4.5x0.1 Shim
- 1 x M1.6X10 Hex Cap Screw
- 4 x M1.6X5 Hex Cap Screw
- 1 x Tail Case Rod

SP-OXY2-036 - OXY2 -
CNC SST Tail Belt Tensioner



- 1 x OXY2-Tensioner Bushing
- 2 x 2X5X2 Radial Bearing
- 1 x 2x3.5x0.1 Shim
- 1 x M2X12 Hex Cap Screw

SP-OXY2-131
OXY2-Vertical Fin for PL Tail Case, Set



- 1 x OXY2-Vertical Fin
- 1 x 2x3.5x2.2 Bushing
- 1 x OXY2-Vertical Fin Bushing
- 2 x 2.5X6X2.6 Radial Bearing
- 1 x 2.55x4.5x0.1 Shim
- 3 x M1.6X5 Hex Cap Screw

SP-OXY2-120
OXY2 - PL Tail Pitch Slider



- 2 x OXY2-Tail Pitch Slider Bushing
- 2 x OXY2- Tail Pitch Slider Ring
- 4 x 3x7x2 Radial Bearing
- 2 x OXY2-Tail Pitch Slider Haft Moon
- 4 x M1.4x5 Pan Head Screw

SP-OXY2-040 - OXY2 -
Tail Pitch Slider - Service Bag



- 2 x OXY2-Link Control
- 2 x OXY2-Link Control Buhing
- 2 x M1.4x4 Pan Head Screw

SP-OXY2-083
OXY2-FE - Stretch Tail Push Rod



- 1 x std tail push Carbon Rod
- 2 x OXY2-Tail Push Rod Terminal
- 2 x Plastic Linkage Ball 3mm
- 2 x Threaded Rod M1.4X7mm
- 1 x Guide Push Rod
- 2 x M2.5 Pin Screw

SP-OXY2-042 - OXY2 -
CNC Aluminum Tail Servo Mount- Set



- 2 x CNC Tail Servo Mount
- 2 x 1.6x3.5x0.5 Washer
- 4 x M1.6X5 Hex Cap Screw

SP-OXY2-043 - OXY2 -
Tail Case Hub, Set

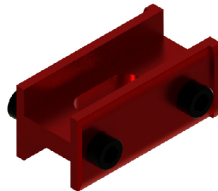

- 1 x OXY2-Tail Case Center
- 4 x M1.6X5 Hex Cap Screw

SP-OXY2-082
OXY2 - Stretch Tail Boom, 2Pcs



- 2 x OXY2 std tail Boom

SP-OXY2-065 - OXY2 -
Tail Bell Crank - Service Bag



- 2 x OXY2-Bell Crank Pin Screw
- 1 x Linkage ball 3x1.5mm
- 1 x M1.6X10 Hex Cap Screw

SP-OXY2-084 - OXY2 Stretch Tail Belt



- 1 x 330T Timing Belt
- 1 x Front Boom Insert

**SP-OXY2-012 - OXY2 -
Blade Holder**



1 x OXY2 Blader Holder

**SP-OXY3-015
OXY2/3/4 - Battery Oring , 4PC**



4 x Oring 55W2.5

**SP-OXY2-045 - OXY2 -
190mm Carbon Plastic Main Blade**



2pcs 190mm Carbon Plastic Main Blade

**SP-OXY2-046 - OXY2 -
38mm Tail Blade, Black**



2pcs 38mm Tail Blade, Black

**SP-OXY2-047 - OXY2 -
41mm Tail Blade, Black**



2pcs 41mm Tail Blade, Black

**SP-OXY2-139
OXY2 - Straight Pinion 11T, 12T -
2mm Motor Shaft**

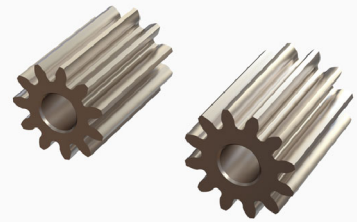

1 x Pinion 11T 2mm Motor Shaft
1 x Pinion 12T 2mm Motor Shaft

**SP-OXY2-140
OXY2 - Straight Pinion 13T, 14T
2mm Motor Shaft**

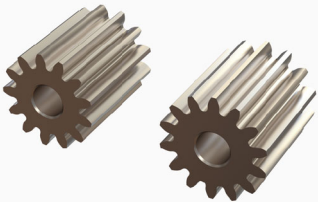

1 x Pinion 13T 2mm Motor Shaft
1 x Pinion 14T 2mm Motor Shaft

**SP-OXY2-141
OXY2 - Straight Pinion 11T, 13T
2.5mm Motor Shaft**

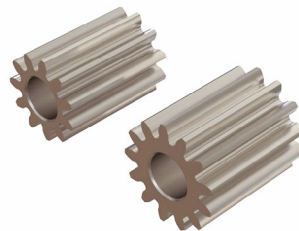

1 x Pinion 11T 2.5mm Motor Shaft
1 x Pinion 13T 2.5mm Motor Shaft

**SP-OXY2-142
OXY2 - Straight Pinion 15T, 17T
2.5mm Motor Shaft**

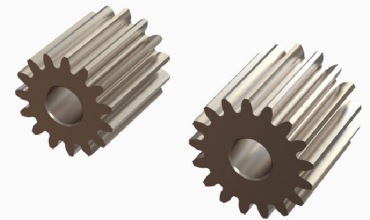

1 x Pinion 15T 2.5mm Motor Shaft
1 x Pinion 17T 2.5mm Motor Shaft

**SP-OXY2-064 - OXY2 -
3D Leveler Tool**

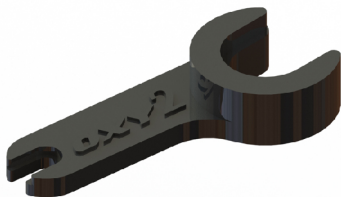

1 x Leveler Tool

**SP-OXY2-063 - OXY2 -
Fiber Glass Canopy Schema # 1**



1 x Orange Canopy

**SP-OXY2-061 - OXY2 -
Vertical Fin Sticker White**



1 x Vertical Fin Sticker White

SP-OXY2-062 - OXY2 -
Vertical Fin Sticker Green



1 x Vertical Fin Sticker Green

SP-OXY2-059 - OXY2 -
Vertical Fin Sticker Yellow



1 x Vertical Fin Sticker yellow

SP-OXY2-060 - OXY2 -
Vertical Fin Sticker Orange



1 x Vertical Fin Sticker Orange